



# ROAR

April, 2021

Volume 21, Issue 4

### Inside This Issue

<b>PRESIDENT'S POINT</b>	2
<b>KAUTION KORNER</b>	2
<b>OIL SPOTS</b>	4
<b>RIDING TIPS</b>	9
<b>Birthdays and Spirit</b>	10
<b>COP THINGS</b>	11
<b>GENERAL MEETING</b>	12
<b>BOARD MEETING</b>	13
<b>VP's Vision</b>	14
<b>Business Mart</b>	15
<b>Top Cats Patrons</b>	16
<b>Rides and Events</b>	17
<b>TC Organization</b>	18

### Upcoming Events

- APRIL**
- 6 GENERAL MEETING
  - 13 BOARD MEETING
  - 17 SHOOT OUT
  - 17 GRASS CLASS
  - 18 TAFT TESTIMONIAL RIDE
  - 24 CPR CLASS

- MAY**
- 5 GENERAL MEETING
  - 12 BOARD MEETING

Talk to Greg Smith and Jim Purcell and get your ideas on the calendar!





## PRESIDENT'S POINT



### And Now a Word from your President...

Hello Top Cats! I hope you and your families are well and you are managing to keep your sights on the riding season ahead as we move through this EVER lingering health crisis. As I mentioned at this time last year, my favorite quote from Winston Churchill is, "If you're going through hell, keep going". So, keep going....

As is every spring when the weather is unpredictable, now is a great time to review your riding gear and equipment and to clean, fix or replace what is old, missing or damaged. This goes for you too. Time to get moving so the transition from couch or home office chair is easier when you're out riding.

And after you are done attending to your gear and yourself, take some time to look over the Top Cats website, review the calendar taking time to write dates in your personal calendar as well as making sure to **highlight 6/13 for the Ride for Dreams**. Also, look over the pictures from past years and the ROARs. There are lots of great memories there and more to come in the near future. We will be out on the road sharing adventures and telling stories of how we spent our shelter time. Ask about mine and I'll show you pictures.

Our calendar already has several events listed, and more are to be added soon.

Currently:

- April 17th Shootout at On Target (Case)
- April 18th Kick-off ride (Bradbury)
- April 24th First-aid/CPR (DeLordo)
- May 8th Picnic ride (Rigsby)

This is why Top Cats - Illinois is the premier motorcycle riding club in the Chicagoland area.

Please feel free to reach out to me at anytime via my email: [Gene.rigsby@gmail.com](mailto:Gene.rigsby@gmail.com), or phone, 847-770-9425.

Looking forward to seeing you there....  
Gene "Lucky" Rigsby

## KAUTION KORNER

# Gearing up for That First Spring Ride!

By: Gene "Lucky" Rigsby  
Senior Road Captain

- ✓ **T** **Tires.** Check air pressure, wheels, brakes and spokes.
- ✓ **C** **Controls.** Check levers, hoses, cables and throttle.
- ✓ **L** **Lights and electrical switches.** Make sure all are working properly.
- ✓ **O** **Oil and fluids.** Check oil, coolant and hydraulics. Look for leaks.
- ✓ **C** **Chassis.** Check drive train, chain and suspension. If you add a passenger, adjust accordingly.
- ✓ **S** **Side stand (Kickstand).** Make sure spring and stand operate reliably.

As I mentioned in my President's Point article this month, we should all have a bit of extra time this year to attend to our gear and our equipment before we head out on the roads. To help you get started, here is some tried and true insight and direction.

TCLOCS is an acronym, which was created by the MSF (Motorcycle Safety Foundation) to help riders remember to check and verify the condition and function of critical systems of your bike, including Tires and Wheels, Controls, Lights and Electrical, Oil and Fluids, Chassis and Side stand. There are variations of TCLOCS I have heard of, but this a base.

(Continued on page 3)



## KAUTION KORNER

KK, continued...

Your owners manual will have much of the information you will need to perform TCLOCS, but you may need to look online, purchase a shop manual or ask the service folks at your local dealership.

Below are the basics to check.

- |                      |              |
|----------------------|--------------|
| T (tires and wheels) | <i>Easy</i>  |
| Tread                | <i>Tread</i> |
| Pressure             | <i>Test</i>  |
| Rubber condition     |              |



- |                                      |  |
|--------------------------------------|--|
| C (Controls)                         |  |
| Tight/Proper adjustment              |  |
| Cables in good condition/Lubrication |  |
| Brake / Clutch fluid                 |  |

*Find a good  
Guide Book*



- |  |  |
|--|--|
| L (Lights and electrical)                              |  |
| Headlight (low/high beams)                             |  |
| Directions indicators (Left and Right, Front and Rear) |  |
| Stop/Plate   |  |
| Dash/fairing/gauges lighting                           |  |

*Adjust  
Your  
Headlight  
Focus!*

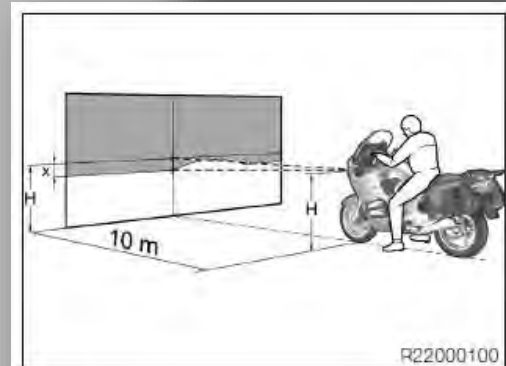

**Setting for headlight beam angle adjuster**  
 X= .....-10 cm (-3.9370 in) for 10 m (32.8 ft) distance  
 H= ..... Height to centre of headlamp

- |                          |  |
|--------------------------|--|
| O (Oil and Fluids)       |  |
| Check engineer oil level |  |
| Check clarity            |  |

- |                                   |  |
|-----------------------------------|--|
| C (Chassis)                       |  |
| Handlebars                        |  |
| Head bearing smooth but not loose |  |

- |  |  |
|--|--|
| S (Side stand)                                   |  |
| Make sure it moves smoothly. Lubricate as needed |  |

By performing TCLOCS at the beginning of the season and every time you ride, you can greatly reduce the possibility of having issues on the road and we all like that.

Looking forward to seeing you there...

## Oil Spots

By Traveler



Considering customer convenience, standardization of swappable batteries and wide adoption of battery systems is vital, which is why the four member manufacturers agreed to form the Consortium.

Executive Officer Takuya Kinoshita, Chief General Manager of Motorcycle Business Operations, Yamaha Motor Co.,

### Swappable batteries consortium formed by four OEMs



Honda announced that the company has signed a letter of intent with KTM AG, Piaggio & C SpA and Yamaha Motor Co., Ltd. to set up a Swappable

Batteries Consortium for Motorcycles and Light Electric Vehicles.

In the context of the Paris Climate Agreement and the transition to electromobility, the founding members of the Consortium believe that the availability of a standardized swappable battery system would promote the use of light electric vehicles and contribute to sustainable management of batteries used in the transport sector.

Extending the range, shortening the charging time and lowering vehicle and infrastructure costs, the manufacturers will answer customers' main concerns regarding the future of electromobility.

By working closely with interested stakeholders and national, European and international standardization bodies, the founding members of the Consortium will be involved in the creation of international technical standards.

"The worldwide electrification effort to reduce CO2 on a global scale is accelerating, especially in Europe," said Noriaki Abe, Managing Officer of Motorcycle Operations for Honda Motor Co., Ltd. "For the widespread adoption of electric motorcycles, problems such as travel distance and charging times need to be addressed, and swappable batteries are a promising solution.

Ltd. said: "I believe the creation of this Consortium holds great significance not just for Europe but the world as we move towards establishing standards for swappable batteries for light electric vehicles. I'm confident that through work like this, the technical specs and standards that currently differ by regional characteristics or the state of the industry in different markets will be unified, and, in the future, will help lead towards maximizing the merits of electric power for customers on a global level."



### 2021 Chieftain Elite



Indian Motorcycle unveiled the latest in its "Elite" lineup of ultra-premium, limited edition motorcycles with the 2021 Chieftain Elite. Combining unmatched power with bold, custom-inspired styling, the 2021 Chieftain Elite was designed for riders who demand the best of the best and want to stand out from the crowd. Its limited run of only 120 worldwide make it Indian Motorcycle's most exclusive Elite model yet.

(Continued on page 5)



The Chieftain Elite's premium two-tone Thunder Black Vivid Crystal over Carbon Crystal paint delivers a custom-inspired aesthetic. Premium finishes, such as the Thunderstroke 116's Slate Smoke finish and color-matched badging throughout set the Chieftain Elite apart from any other bagger on the road.

The 2021 Chieftain Elite touts exclusive styling, premium amenities and easy-to-use technology. Each Chieftain Elite undergoes a meticulous paint process that takes more than 24 hours to complete by hand. From the gunmetal flake layered within the paint to the Slate Smoke engine finishes this premium bagger has a custom feel with utmost attention to detail.

For touring and comfort, riders can select from a variety of handlebars and seats, including a Low Profile Quick Release Passenger Sissy Bar and Backrest Pad, as well as a color-matched, remote-locking trunk and color-matched hard lower fairings with adjustable air vents.

Riders can explore Indian Motorcycle's Thunderstroke 116 Stage 1 and Stage 2 offerings. The Stage 1 Slip-On Exhaust Kit and Stage 1 Oval Slip-On Muffler Kit deepens the exhaust note while unleashing power. By pairing the Thunderstroke Stage 1 Performance Air Intake or Thunderstroke High-Flow Air Intake with the exhaust or muffler kits, riders will increase horsepower by 8%.

As standard equipment, the 2021 Chieftain Elite has Pathfinder LED lighting, a tinted flare windshield with push-button power, spacious aluminum select floorboards and an integrated 400-watt PowerBand audio system.

Taking center stage is Indian Motorcycle's seven-inch Ride Command infotainment system. Riders can view weather and traffic overlays, while Apple CarPlay delivers a customized level of control for music, navigation preferences and mobile device information.

As Indian Motorcycle's most powerful air-cooled engine, the Thunderstroke 116 delivers class-leading performance with 126 ft-lbs of torque. Rear cylinder deactivation improves rider comfort when traversing through slower traffic, and three selectable ride modes, including Tour, Standard and Sport, allow riders to adjust the bike's throttle response. The throttle map for each ride mode was designed with a specific application in mind, resulting in one motorcycle with three distinct personalities.

Available now at Indian Motorcycle dealers, pricing for the exceptionally exclusive Chieftain Elite starts at \$34,999 in the U.S. and \$42,999 in Canada.

## [Brough Superior Unveils 2021 Lawrence](#)

For those wondering what on earth happened to the revival of Brit brand Brough Superior, here's a couple of



answers. The first is, the pandemic knocked it off track; the second is, the company has regrouped and is back with a brand-new bike.

The now French-based marque has just released its latest model, the Lawrence, a hand-built two-seater named after one of the brand's most famous and ardent fans, Colonel Thomas Edward Lawrence, (Lawrence of Arabia) who owned seven Brough Superior motorcycles in his time.

Brough expects the new bike to make waves; it's a departure from the classically styled bikes that more closely echoed the original company's low-slung designs. The new Lawrence is more trim, refined, and modern in tone, with curvier new carbon fiber bodywork and a new fuel tank with raised "brows" to set it distinctly apart from its stablemates. Brough says the tank's lines are designed after "the curved daggers Bedouins wore on their belts and pictured on Lawrence of Arabia".

The Lawrence brings some unique engineering, exotic materials, and high-tech components to the table. There's a titanium frame, further bolstered by a titanium subframe; a Fior-type fork CNC-machined from aluminum with titanium links connecting to a centrally mounted monoshock; a cast aluminum swingarm that pivots in the engine crankcases, also joined to an adjustable monoshock; and machined aluminum wheels with a dual-disc Beringer brake setup upfront. All that aluminum helps keep claimed weight down to a featherweight 440 pounds.

(Continued on page 6)



# ROAR

Oil Spots, continued...

Brough Superior being a small-volume maker of hi-end bikes, uses certain components that are shared across the line. One is that 997cc, water-cooled, eight-valve,



DOHC motor, a version that Brough uses in its other bikes, originally built for Brough by Boxer Design. The V-twin unit is set at 88 degrees and produces 102 hp at 9,600 rpm and 64 pound-feet of peak torque.

Hand-built bikes made of top-shelf materials don't come cheap, and this one will set you back approximately \$79,083. And that's provided you can get one; Brough is minting just 188 of this model, as a tribute to T.E. Lawrence's birth year of 1888.

## Futuristic AUTOMATIC DE-ICING ROAD IN FRANCE

A French company named Eurovia announced a new type of tech that allows a road to heat itself in winter to clear snow and ice.



The road is built around the basic principle of a heat exchanger and is similar to the pipes you find in under-floor heating. Fluid is passed through pipes and depending on the road's ambient temperature energy can either be taken from or sent to the road's surface layer.

Because of the natural propensity for roads to absorb heat -- being black and facing directly upwards -- the system can also take in heat during the summer, store it and then release it in the winter. This could help clear obstructions like ice or snow, or the energy could be diverted into heating nearby homes or buildings.

This project has advanced beyond the drawing board,

with Eurovia already building an actual working version of the new "Power Road" tech, located along a 120m stretch of road recently opened in Égletons, France.

The region has seasonal hot and cold weather, making it a perfect



urban environment to try the road out. With some flurries of snow, the automated road managed to clear snow and ice before it reached such a level that vehicles would have been inhibited.

While Eurovia clearly didn't set out to make it easier for motorcyclists to ride in the winter, that could be a very real bonus to its Power Road installations.

## Honda Developing Bike-mounted Drone

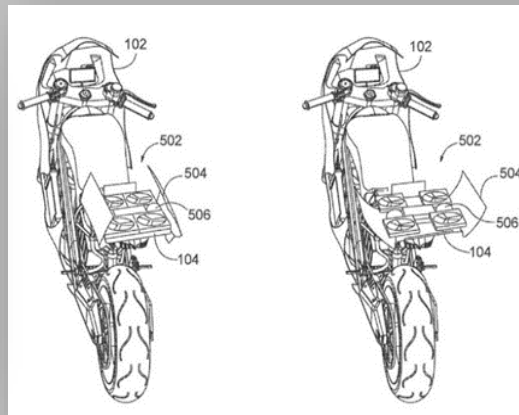

In the future, your brand-new Honda motorcycle may come complete with its own built-in drone.

Honda's R&D department

has filed a patent application for a motorcycle-mounted drone, though it's clearly a very long-distance vision of the future.

The patent document describes a drone with four rotors that sits in a housing in the extended tail of a motorcycle. The idea is that it's a completely autonomous flying machine that can be released on command and return automatically to the bike when needing a recharge.

Among the potential purposes of the drone, Honda suggests it could be used to deliver fully charged battery packs to an electric motorcycle—solving the range problem of electric bikes—though there's no clear mechanism for actually swapping the packs

(Continued on pg. 7)



Oil Spots, continued...

and given current technology it's impossible to imagine a quadcopter that's both small enough to fit on a bike and big enough to carry a battery able to propel the same bike.

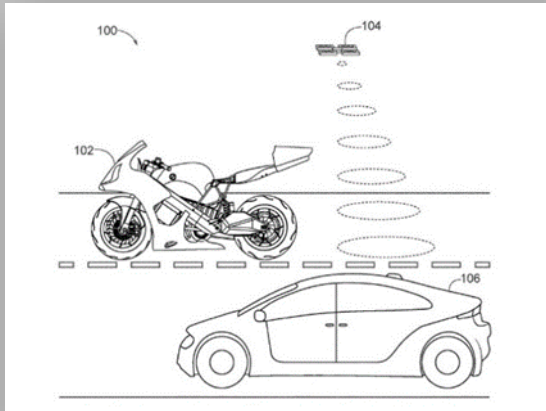

One of its uses could be as a traffic-monitoring, eye-in-the-sky system that could feed info

on conditions back to the rider.

A more realistic suggestion is that the drone could work as part of a traffic monitoring system, watching the road ahead and feeding information back to the bike's rider to warn of problems before they come into view at ground level.

The drone is also suggested as a sort of communications relay, extending the range of systems on the bike itself or alerting emergency services in the

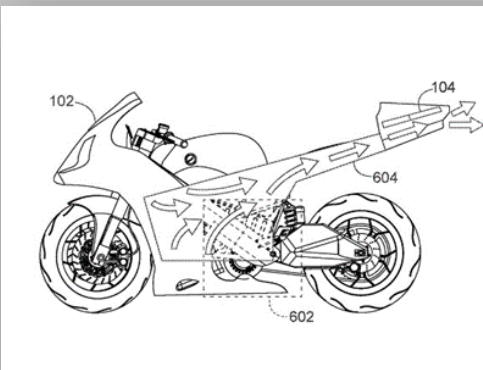

event of an accident, and Honda even says that while docked it could be incorporated into the bike's cooling



ing system, using the rotors as fans to suck air past a radiator. It's also worth noting that Honda's patent clearly shows the drone fitted

to an electric sportbike.

Of course, this isn't the first time that bikes and drones have been put together. Honda was beaten to the punch by none other than Ural, which created a sidecar with a built-in DJI Spark quadcopter back in 2018.

Like Honda's patent, the Ural design suggested the drone could be used as a scout, checking out what lies ahead before it's in the rider's sightline.

Unlike the Honda, the Ural was a complete machine, but the drone wasn't fully automated—the passenger operated it from the sidecar, using a display on his remote control to see the drone's eye view ahead.

## [Harley-Davidson Is Making A Big Bet On Used Bikes](#)



Younger people aren't buying many Harley-Davidsons and haven't been for years, because Harleys are expensive and not as popular as they used to be making the decision to kill their cheap bikes earlier this year a head-scratcher. Now, Harley has a plan to fill that void.

Harley says it is starting a certified pre-owned program. Lightly-used Harleys will have 12-month warranties. These Harleys are intended to replace Harley's entry-level option for new riders, and attract more riders to the Harley brand.

It is called H-D Certified. Certified motorcycles will be less than five years old, with fewer than 25,000 miles. H-D Certified Harleys can be financed through Harley. H-D Certified will be here as soon as next month. "We believe this program will drive Harley-Davidson desirability, increase sales and margins, and enhance the overall customer experience while supporting growth," CEO Jochen Zeitz told Reuters.

(Continued on pg. 8)



Oil Spots, continued...

A booming demand for pre-owned Harleys has been a drag on the company's U.S. sales, which have declined by nearly 40% since 2014.

As its motorcycles do not wear out or go out of fashion quickly, used Harleys tend to be more in demand vis-à-vis pricey new models.

Zeitz has tried to address the problem in the past year by tightening the supplies of new bikes. Less new inventory has driven up the prices of pre-owned bikes.

Still, the company estimates there are 3 million unsold used Harleys in the United States, far more than the approximately 80,000 new bikes it shipped last year.

"The biggest competition for a new Harley-Davidson bike is not an Indian or a Honda, or a Suzuki, but is a used Harley-Davidson bike," said Zeitz.

Reuters goes on to make the point that the rise of certified pre-owned in the 1990s led many automakers to ditch entry-level cars which tracks with Harley's decision earlier this year to discontinue its Street 500, Street 750 and Street Rod bikes, which cost \$6,899, \$7,599, and \$8,699, respectively.

The idea is that buyers might now gravitate toward H



-D Certified, and a good chunk of those will finance those purchases, as another revenue stream for Harley. But weight will remain somewhat of a deterrent for younger riders. A Harley is still a heavy motorcycle, and, unless you're already into that sort of thing, this won't change the situation much.

Still, for the short-term, this seems likely to make business sense, since Harley wasn't making a whole lot of money on the cheap bikes.

## [Honda 2022 Grom](#)

In 2014, Honda debuted the Grom. The pint-sized 125cc fun you could have a good time with in your own backyard.

The Grom 2022 model brings alterations that riders have wanted.

Body panels are quick-release, a handy feature for those who crash a lot and for those who desire to add their own flair with a vinyl wrap or custom paint. The seat has more padding and retains a low, 30-inch height. The fuel tank jumps in capacity to 1.59 gallons.

The powerplant displaces 125cc but sports an updated transmission with wider gear ratios and a fifth gear. Highway speeds *are* possible and having some extra rpm in top gear helps make the Grom more versatile. Engine compression goes from 9.3:1 to 10:1. Another upgrade is a replaceable oil filter in place of the previous oil-spinner and screen.



The 2022 Grom is an evolution of the modern fun machine. For commuting or for a two-wheeled pocket-rocket, it's hard to beat the Grom's \$3399 price tag (\$3599 if you opt for the ABS model).







## 2021 Riding Tips

By Traveler



Masks. With COVID, carry a zip lock bag with a few **spare masks**.

Carry a small dispenser of **hand sanitizer**.



Set your **clock** and any electronic devices to Daylight Savings Time.



Update **GPS**. Check out your GPS manufacturer for firmware / software / map updates.



Freshen up your **helmets**. Place dryer sheet fresheners in helmets and any other items like **jackets**, etc, to freshen the **ü**

Update your **intercom**. Check out your intercom manufacturer for firmware / software updates to



your intercom.

Check out your **helmet visor**, **night glasses**, **goggles** for scratches or defects before your first ride this year.



**Rubber gloves**. If you carry rubber or latex gloves for emergency purposes, or for riding in the rain, replace them. Rubber will wear out fast when stored.



Check for updates to your bikes' **maps**, **software** and **dealer data-base**.



(Continued on pae10)



Tips, continued...



Check **rain suits**. Check it for fit and overall condition.

Check your first aid kit. Some items may have an expiration date.

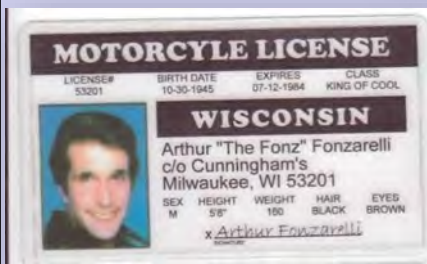

Check MC, FOID, CCL **Licenses**. When do your licenses expire? In the middle of the riding season?

Double check your **insurance** card, your bike registration, and how current your **CPR / First Aid training** is.



Use the **T-Clock** method of going over your bike early enough to have it fixed if you discover a defect.

It should be **common sense**, and almost a habit, to go over the **mechanics of your bike** to assure that all of your **safety items** are working and, your bike is in good mechanical condition so 1.) You can **ride it safely** and, 2.) You **don't become a burden** to your fellow riders by breaking down somewhere



The DeDion-Bouton Motorcycle... Circa 1890. Read more about it on page 14... VP's Vision.

## April Birthdays and Anniversaries!



11 Diana Lanute

Happy Days to our Top Cats Celebrities for April  
Let us know your special Dates so that we can celebrate with you!

No April Love Stories...





## Things You Might Say To, or Hear From, Cops.... By: Traveler



With the riding season right on top of us, we should prepare for encounters with law enforcement officers also.

**Always be friendly and try to start friendly conversations with greetings like:**

- ▶ "Good afternoon, Officer. Weren't you with the Village People?" Or,
- ▶ "Hi, Officer. Wow! I thought you had to be in good physical shape to be a Cop." Or,
- ▶ "Sorry Officer. I forgot my radar detector was unplugged." Or,
- ▶ "Wow. You must have gone over 100 mph to catch me". Or,
- ▶ "Hold my beer and I'll get my license out." Or,
- ▶ "I was going to be a cop, but they found out my parents were married." Or,
- ▶ "I was speeding??? What about you?" Or,
- ▶ "Sorry, Officer, I was on the phone."

**Now, here are a few comments from Law Enforcement Officers:**

- ▶ "You know, stop lights don't come any redder than the one you just went through."
- ▶ "Relax, new handcuffs are tight. They'll stretch after you wear them a while."
- ▶ "If you take your hands off of your helmet before I tell you to, I'll make your birth certifi-

icate a worthless document."

▶ "If you run from me, you'll only go to jail tired."

▶ "You don't know how fast you were going? I guess that means I can write anything I want to on the ticket, huh?"

▶ "Yes, sir, you can talk to the shift supervisor, but I don't think it will help. Oh, did I mention that I'm the shift supervisor?"

▶ "Warning! You want a warning? O.K., I'm warning you not to do that again or I'll give you another ticket."

▶ "The answer to this last question will determine whether you are drunk or not. Was Mickey Mouse a cat or a dog?"

▶ "Yeah, we have a quota. Two more tickets and my wife gets a toaster oven."

▶ "No sir, we don't have quotas anymore. We used to, but now we're allowed to write as many tickets as we can."

▶ "You didn't think we give pretty women tickets? You're right, we don't. Sign here."



Respectfully Submitted  
by:  
Diana Lanute

## GENERAL MEMBERSHIP MEETING MINUTES MARCH 2ND, 2021



### Announcements:

- 3/9 Rich Lanute's Birthday
- 3/25 Greg and Jane Smith's Anniversary
- 3/24 Cindy DeLordo's Birthday

### President: Gene Rigsby

- ✦ 7:00 pm, Meeting called to order
- ✦ The members stood for the Pledge of Allegiance
- ✦ Guests: Doug Jackson, owner of Woodstock Harley Davidson
- ✦ Mike Gilfillan – Relocating to Franklin, TN. All wished him well and he promised to ride with us when he can!

### Vice President: Mary Kirkpatrick

- ✦ Nothing to report tonight.

### Past President: Wayne Kirkpatrick

- ✦ Bill Yates came home but had to return to the nursing home. Bill's wife is interested in selling his motorcycle but hasn't settled on a price as yet.

### Safety: Ted Makarewicz

- ✦ Kaution Korner - Be sure to wear all your safety gear all the time. Ted also discussed putting together a safety kit. Do check expiration dates on the contents. The complete Kaution Korner article in March issue of ROAR.

### Safety Video: Gene Rigsby. No Video as we have a guest speaker

### Membership: Ted Makarewicz

- ✦ New membership cards mailed to members.

### Activities: Jim Purcell / Greg Smith

- ✦ Recent activities – None.
- ✦ Future activities
- ⇒ A Road Captain meeting is scheduled for March 14, 2021. Any members interested in becoming a Road Captain, please contact Gene.
- ⇒ Our "Ride for Dreams" to benefit NISRA is scheduled for June 13, 2021. The Volo Auto Museum will allow us to use their location as our final destination.
- ⇒ Sturgis – Bard (reported by Wayne) has one more room available.
- ⇒ Front Range Ride (post Sturgis ride) was reviewed by Wayne.

### Charity

- ⇒ New director – Gene discussed available position

### Special Guest: Doug Jackson

- ⇒ Our special guest speaker at our general meeting was Doug Jackson from Woodstock Harley Davidson. Doug spoke on WSHD restructured business and what differentiates this dealer from others is less stress when looking to buy a motorcycle and the financial advantages of a large, successful dealership. He noted there will be no collaboration between dealerships.
- ⇒ The market share is very strong now; HD is up 16%, and an all-time record in 2021 is expected at Woodstock Harley Davidson. Doug said last year 1200 (new and used) bikes were sold at our dealership. Unfortunately, there may be a couple of dealerships that will be closing in 2021.
- ⇒ Doug also fielded questions from our membership this evening regarding customer service and a new corporate plan called "Hardwire," as well as plans for later in the year which include Thursday night "bike nights".
- ⇒ Of note, Shelley, a valued salesperson at WSHD recently had surgery, she is doing well and is back to work.

### Products: Ted Makarewicz

This position is available now and Ted has accepted the position.

### 50/50 Raffle: Jim Purcell

Joey Rizzo won and donated his winnings to the Charity Fund.

Meeting Adjourned at 8:10 p.m. by Gene Rigsby



Respectfully Submitted  
by:  
Diana Lanute

## BOARD MEETING MINUTES MARCH 9TH, 2021

**President: Gene Rigsby**

✦ 7:00 pm, Meeting called to order

- ✦ Immediate needs? None.
- ✦ Quarterly meetings – Discussion held on whether to have regular meetings every month or to hold board meetings as needed or call for alternating monthly meetings. At this time, the board will continue with monthly meetings.
- ✦ 25 year service – We will celebrate 25 year service awards at our Banquet on 9/11/2021 for Bard Board, Wayne Kirkpatrick, Ric Case and Tom Malia

**Past President: Wayne Kirkpatrick**

- ✦ Sturgis/Front Range Ride seminar – Ride is full! Wayne gave an update.

**Vice President: Mary Kirkpatrick**

- ✦ Website will be brought up to date with products, pictures and editions of ROAR.

**Activities: Greg Smith**

- ✦ Future Events
- ✦ RC Committee meeting on March 14.
- ✦ Ride for Dreams, Volo Auto Museum on June 13, discussion held.
- ✦ Pancake Breakfast – Planning/discussion held regarding first Saturday of each month, 9-11 AM, to be held at Woodstock Harley Davidson dealership. This could be shared with Rolling Thunder Ch2-IL and Top Cats hosting alternate months during riding weather. Top Cats could put up their booth and possibly pull in new members.
- ✦ Banquet Date – Saturday, September 11.
- ✦ Picnic Date – May 8 at Gene's. Bring your meal. Gene and Noelle will have drinks and a campfire.
- ✦ Shootout – No date from Ric. Gene to check with Ric.
- ✦ Gene has offered us the October campfire again this year.

**Safety: Ric Case**

- ✦ Ric is not here and Don reviewed his notes. CPR/First Aid/AED - You cannot take in-person test until you take on-line test. Non-member cost \$80; TC \$40 (club pays \$40).
- ✦ GRASS – Don to follow up with Ric on members who must take this.
- ✦ Road Captain Committee Meeting – March 14.
- ✦ Ben C. – Gene to contact him about speaking at GRASS class.

**Membership/Products: Ted Makarewicz**

- ✦ 25<sup>th</sup> Anniversary – Does anyone have ideas on how to commemorate the event??
  - ⇒ Patches – Club items for sale reviewed
  - ⇒ Picnic – May 8 – Members will be asked to share memorable thoughts on rides.
- ✦ Waiver review – The board discussed attaching a waiver review to the dues statement every year. It was agreed that we will continue to do this and then scan in the documents each year for a digital record.

**Charity / Products: Open**

- ✦ Mary to give some help with Charity.
- ✦ Mike Bradbury is considering Director of Charity position.
- ✦ Volo Auto Museum - There was a discussion about having a 50/50 Raffle – Half of winnings should go into charity account and the other half would pay for the museum tickets if we can have access.

**Treasurer: Don DeLoro**

- ✦ Regarding Bill Yates – Top Cats to send \$150 check to charity of choice. His paid membership dues of \$75 are part of the charity donation.

**Secretary: Diana Lanute**

- ✦ Secretary agreed with quarterly meetings to be called alternate meetings if we change.

**Meeting Adjourned by Gene Rigsby at 8:12p.m.**



## A Little More History.... DeDion-Bouton

### V.P.'s Vision

By: Mary 'Trooper' Kirkpatrick

In looking for things to read and write about, this article popped up... Another piece of history that has influenced our beloved American sub-culture of motorcycles! This story is set in France, but I find it interesting and motivating to read about curious people with dreams, which seems to be a common substance of our Top Cat Family Members...

**De Dion-Bouton** was a French automobile manufacturer and railcar manufacturer operating from 1883 to 1953. The company was founded by the Marquis Jules-Albert de Dion, Georges Bouton, and Bouton's brother-in-law Charles Trépardoux.

The company was formed after de Dion in 1881 saw a toy locomotive in a store window and asked the toymakers to build another. Engineers Bouton and Trépardoux had been eking out a living with scientific toys at a shop in the Passage de Léon, near "rue de la Chapelle" in Paris. Trépardoux had long dreamed of building a steam car, but neither could afford it.

De Dion, already inspired by steam (in the form of rail locomotives) and with ample money, agreed, and **De Dion, Bouton et Trépardoux** was formed in Paris in 1883. This became the De Dion-Bouton automobile company, the world's largest automobile manufacturer for a time, becoming well known for their quality, reliability and durability.

By 1889, de Dion was becoming convinced the future lay in the internal combustion engine, and the company had built a ten-cylinder two-row rotary. After Trépardoux resigned in 1894, the company became *De Dion, Bouton et Compagnie*. For 1895, Bouton created a new 137 cc (8.4 in<sup>3</sup>) one-cylinder engine with trembler coil ignition. Proving troublesome at its designed speed of 900 rpm (throwing bearings and running rough),<sup>[5]</sup> when Bouton increased the revs, the problems vanished. In trials, it achieved an unprecedented 3500 rpm, and was usually run at 2,000 rpm, a limit imposed by its atmospheric valves and surface carburettor. Inlet and exhaust valves were overhead, and a flywheel was fitted to each end of the crankshaft.

This engine was fitted behind the rear axle of a **tricycle frame** bought from Decauville, fitted with the

new Michelin pneumatic tires. It showed superb performance, and went on the market in 1896 with the engine enlarged to 1¼ CV

(Horsepower)  
(932 W)  
185 cc  
(11.3 cu in),  
with 1¼ CV  
(1.3 kW) in  
1897. By the  
time production  
of the *petite voiture* tricar



stopped in 1901, it had 2¾ CV (2 kW), while racers had as much as 8 CV (6 kW).

In 1898, Louis Renault had a De Dion-Bouton modified with fixed drive shaft and ring and pinion gear, making "perhaps the first hot rod in history".

The De Dion-Bouton engine is considered to be the first high-speed lightweight internal combustion engine. It was licensed to more than 150 manufacturers and was a popular choice among assemblers of moto bicycles. The small lightweight four cycle engine used a battery and coil ignition that was less trouble than the hot tube ignition. The bore of 50 mm (2.0 in) and stroke of 70 mm (2.8 in) gave this engine an output of 1 kW (1.3 hp). It was used on many pioneering moto bicycle brands and was widely copied by many makers including US Brands Indian and Harley-Davidson.

To read more about this company and the influence in the car industry as well, go to:

[De Dion-Bouton - Wikipedia](#)

**Top Cats Buy, Sell, Trade....**  
*The best way to ensure good quality at fair prices!*

**GREAT DEALS!**

Put your items here and get the word out that you have stuff to sell!



## TOP CATS BUSINESS MART

*BUSINESSES OWNED AND/OR MANAGED BY TOP CATS MEMBERS*



CHASE PRIVATE CLIENT



**Lisa Purcell**  
Mortgage Banker  
NMLS ID: 817405

1289 S. Rand Rd  
Lake Zurich, IL 60047  
Telephone: 847 857 0913  
lisa.a.purcell@chase.com  
JPMorgan Chase Bank, N.A.

**GEAR  
UP  
FOR  
SPRING  
RIDING**

**Coming  
Soon....**

**Let's  
hope!**

**Network with  
your fellow  
Riders here...**



## Support the TOP CATS Patrons



Doug Jackson and Staff Support our Top Cat's Ride for Dreams!



**PALATINE, IL**

Home to Alley 64,  
Top Cat's Monthly Meeting Spot!

GRASS Classes are held at the Keller -Williams Offices!

Thanks, Greg for supporting our Top Cat's Safety Class!

### Membership Has Its Privileges!

All suppliers and vendors who support the Top Cats by providing discounts to Top Cats members will be listed in ROAR.

*Sign-up your favorite merchant today!*



**Greg Smith**

**Keller - Williams Success Realty**

600 Hart Rd.  
Suite 105  
Barrington, IL 60010

847.870.0957

Have one of our own Top Cats work with you to buy or sell your home!



When we are released from our quarantine, let's remember Alley 64 and get back there quickly!







## RIDES & EVENTS

Date	Ride/Event	Location	Destination	Time	Leader
Tuesday, April 6th	General Meeting	Palatine	Alley 64	7:00 pm	Rigsby
Tuesday, April 13th	Board Meeting	Palatine	Alley 64	7:00 pm	Rigsby
Saturday, April 17th	Shoot Out	Crystal Lake	On Target	7:30 am	Case
Saturday, April 17th	GRASS Class	Woodstock	Woodstock HD	11:00 am	Cae
Sunday, April 18th	Taft Testimonial	BP Amoco, Wauconda	Variety of Stops	8:15 am	Bradbury
Saturday, April 24th	CPR Class	Woodstock	Woodstock HD	Two Sessions	Case
Tuesday, May 4th	General Meeting	Palatine	Alley 64	7:00 pm	Rigsby
Tuesday May 11th	Board Meeting	Palatine	Alley 64	7:00 pm	Rigsby
Watch for	rides to be	added to	our calendar!	Check there	for details!

All ride and event information along with the Photo Gallery can be found at [www.TopCats.org](http://www.TopCats.org).



### **Barrington Library**

**Location and Hours**  
505 N. Northwest Highway  
Barrington, IL 60010

847-382-1300  
balibrary.org

See the Top Cats Archive

## **FREE ADVERTISING in ROAR for TOP CATS Business Owners**

***Attention all Top Cats business owners!***

As part of our ongoing philosophy to support our members and goal to provide a more value-rich publication, we are now offering free advertising space in ROAR for Top Cats business owners. Each business owner can submit advertising content and graphics up to 2 X 3.5 inches (Business Card size) for their company.

We will run the ad for 3 months after which you will need to resubmit it.

This offer is for Top Cats business owners only. We are not accepting advertising for other businesses at this time.

Submit your ad along with contact information to the ROAR editors at [ROAR@TOPCATS.org](mailto:ROAR@TOPCATS.org)



# ROAR



**TOP CATS OF ILLINOIS** is a group of motorcycle enthusiasts with similar interests. Members consist of responsible Leaders, Presidents, Chairmen, Owners, Proprietors, Partners, principals, CEO's, and other 'Top Cats' of large, medium and small organizations, institutions, and companies.

For more information about the Top Cats visit our website at [www.TopCats.org](http://www.TopCats.org)

ELECTED OFFICERS & DIRECTORS		COMMITTEE LEADERS		ROAR	
<b>President</b>	Gene Rigsby- gene.rigsby@gmail.com	<b>Activities</b>	Greg Smith GregSmith@kw.com	<b>Executive Editor &amp; Board Liaison</b>	Mary Kirkpatrick Mawalters57@gmail.com
<b>Vice President</b>	Mary Kirkpatrick mawalters57@gmail.com	<b>Archives</b>	Open	<b>Editor-in-Chief</b>	Mary Kirkpatrick mawalters57@gmail.com
<b>Treasurer</b>	Don DeLordo Don_De@att.net	<b>Charity</b>	Lisa Purcell lapurcell128@gmail.com	<b>Publisher</b>	Open
<b>Secretary</b>	Diana Lanute Diana.Lanute@att.net	<b>Membership</b>	Ted Makarewicz Hogski@hotmail.com	<b>ASSOCIATE EDITORS</b>	
<b>Past President</b>	Wayne Kirkpatrick wkirkpa177@aol.com	<b>Awards</b>	Mike Bradbury bradbundy@comcast.net	<b>Executive &amp; Board</b>	Wayne Kirkpatrick wkirkpa177@aol.com
<b>Director</b>	Ric Case Riccase@Comcast.net	<b>Safety</b>	Mike Bradbury bradbundy@comcast.net	<b>Safety &amp; Road Captains</b>	Mike Bradbury bradbundy@comcast.net
<b>Director</b>	Greg Smith GregSmith@kw.com	<b>Website</b>	Mary Kirkpatrick mawalters57@gmail.com	<b>Membership</b>	Ted Makarewicz Hogski@hotmail.com
<b>Director</b>	Lisa Purcell lapurcell128@gmail.com	<b>Products</b>	Lisa Purcell lapurcell128@gmail.com	<b>Charity</b>	Lisa Purcell lapurcell128@gmail.com
<b>Director</b>	Ted Makarewicz Hogski@hotmail.com	<b>SGT at Arms</b>	Jim Purcell Jpurcell333@gmail.com	<b>Events &amp; Calendar</b>	Greg Smith GregSmith@kw.com & Jim Purcell Jpurcell333@gmail.com
<b>Founder</b>	Carl 'Virgo' Bender 1941-2001			<b>Motorcycle Community</b>	Wayne Kirkpatrick wkirkpa177@aol.com

© Copyright 2010 **TOP CATS OF ILLINOIS**  
ROAR is the official publication of the **TOP CATS OF ILLINOIS**  
and is published on the 1st of each month.

The content and opinions expressed in articles are those of the authors and not necessarily those of **TOP CATS OF ILLINOIS**

For questions or to submit comments or articles for publication, contact the editors at [ROAR@TopCats.org](mailto:ROAR@TopCats.org)