



ROAR

November, 2022

Volume 22, Issue 11

Inside This Issue

PRESIDENT'S POINT	2
KAUTION KORNER	2
Oil Spots	4
The Road Less Traveled	8
VP's Vision	8
H-D Recall	11
GENERAL MEETING	10
BOARD MEETING	11
Celebrations!	12
Business Mart	13
Top Cats Patrons	14
Rides and Events	15
TC Organization	16

Upcoming Events

NOVEMBER

- 1 GENERAL MEETING
- 8 BOARD MEETING
- 24 THANKSGIVING

DECEMBER

- 6 GENERAL MEETING
- 13 BOARD MEETING
- 25 CHRISTMAS
- 31 NEW YEAR'S EVE!

HAPPY THANKSGIVING



Thankful for
freedom, open roads, two wheels,
family & friends!

The Official Publication
Of Top Cats Illinois

Talk to Greg Smith and Rick Agrimonti and get your ideas on the calendar!





ROAR

PRESIDENT'S POINT

And Now a Word from your President...



Hello Top Cats!!

Fall is in full bloom. The colors have been fantastic this year. I hope you had a chance to see them first hand before they are gone. Winter is quickly approaching so you need to be ready to take advantage of those clear, warmer days when you can. Hopefully we'll get a chance to meet out on the road.

Thanksgiving is this month, I am reminded how thankful I am of my family and friends and the opportunities to share time with them all. Thanks to all our Top Cat family including our board and committee members who keep our club running into the future.

Buddy Check...

It would be great to hear from you. Let me know how you are keeping busy.

Feel free to reach out to me anytime via my email: gene.rigsby@gmail.com, or phone, 847-770-9425.

Looking forward to seeing you there....
Gene "Lucky" Rigsby



KAUTION KORNER

It is time to consider what safety means... Safety is defined as "the condition of being protected from or unlikely to cause danger, risk, or injury.

A terrific way to increase your safety when riding a motorcycle, is to wear one single piece of gear.

But there are differences in opinions on wearing this gear in the motorcycle community. The subject and consequent actions associated with wearing this object has been proven in multitudes of studies to increase your safety when driving a motorcycle and seems like a logical conclusion to choose this major way reduce your risk for fatality or serious head injuries when riding a motorcycle. There are many advocates for wearing this type of gear and some against it who feel that it should be a rider's freedom to choose whether to wear this type of gear or not.

One Way to Ride Safer on Your Motorcycle

By: Michael Bradbury, Senior Road Captain and Director of Safety



(Continued on Pg 3)



Kaution Korner, Continued

. I do not object to anyone’s freedom of choice. As an American, I believe in our rights of freedom and liberty. But I do believe that wearing this type of gear will reduce some of the risks for significant injury and can save your life.

What I am referring to is wearing a helmet when you ride.

Here are a few statistics to share about motorcycle helmet wearing. There are many , many more reputable sources and studies you can find online supporting that wearing a motorcycle helmet makes you safer when riding your motorcycle. Here is what the Center for Disease Control provides about motorcycle helmet safety:

“Motorcycle crash injuries and deaths are preventable. A universal helmet law is the single most effective way for states to save lives and cost savings related to motorcycle crash injuries.” (1)

“Every year there are thousands of deaths and injuries to motorcyclists involved in crashes. More than 5,500 motorcyclists died (2) on our nation’s roads in 2020, and more than 180,000 were treated in emergency departments for crash injuries. (3)

The economic costs of these injuries and deaths are significant.” (4)

Motorcycle helmets can save lives and reduce injuries

- ◆ Helmets saved an estimated 1,872 lives in 2017.⁵
- ◆ 749 more lives could have been saved if all motorcyclists had worn helmets in 2017.⁵
- ◆ Each year, the United States could save \$1.5 billion in economic costs if all motorcyclists wore helmets.⁵
- ◆ Motorcycle helmets are 37 percent (for riders) and 41 percent (for passengers) effective in preventing deaths.⁶
- ◆ Helmets reduce the risk of head injury by 69%.⁷

It is quite clear, according to CDC and the definition of safety, wearing a motorcycle helmet will make you safer when riding your motorcycle.

So wear a helmet!

References

- ◇ The Community Guide. Motor vehicle-related injury prevention: Use of motorcycle helmets, universal helmet laws. Available at: [https://www.thecommunityguide.org/sites/default/files/assets/MVOI-Motorcycle-Helmets-Laws-Mandating-](https://www.thecommunityguide.org/sites/default/files/assets/MVOI-Motorcycle-Helmets-Laws-Mandating-Use_1.pdf)

[Use_1.pdf](#) pdf icon external icon. Accessed 5 April 2022.

- ◇ National Highway Traffic Safety Administration. Overview of motor vehicle crashes in 2020 (Report No. DOT HS 813 266). U.S. Department of Transportation, Washington, DC; 2022. <https://crashstats.nhtsa.dot.gov/Api/Public/ViewPublication/813266> external icon. Accessed 25 March 2022.
- ◇ Centers for Disease Control and Prevention, National Center for Injury Prevention and Control. Web-based Injury Statistics Query and Reporting System (WISQARS). Atlanta, GA: CDC; 2022. Available at: www.cdc.gov/injury/wisqars. Accessed 25 March 2022.
- ◇ Centers for Disease Control and Prevention, National Center for Injury Prevention and Control. Cost of Injury Data. Atlanta, GA: CDC; 2022. Available at: <https://www.cdc.gov/injury/wisqars/cost/> . Accessed 2 May 2022.
- ◇ National Highway Traffic Safety Administration. Lives and costs saved by motorcycle helmets, 2017 (Traffic Safety Facts. Report No. DOT HS 812 867). U.S. Department of Transportation, Washington, DC; 2019. Available at <https://crashstats.nhtsa.dot.gov/Api/Public/ViewPublication/812867> external icon. Accessed 25 March 2022.
- ◇ National Highway Traffic Safety Administration. Motorcycles (Traffic Safety Facts. Report No. DOT HS 813 112). U.S. Department of Transportation, Washington, DC; 2021. Available at <https://crashstats.nhtsa.dot.gov/Api/Public/ViewPublication/813112> external icon. Accessed 25 March 2022.
- ◇ Liu BC, Ivers R, Norton R, et. al. Helmets for preventing injury in motorcycle riders. *Cochrane Database Systematic Reviews*. 2008;(1):CD004333. <https://doi.org/10.1002/14651858.CD004333.pub3> external icon



Oil Spots

By Traveler



6 essentials for your travel toolkit



Don't let the fall colors scare you into putting away your bike for winter just yet. Color tours are spooling up all over and as the temps drop that means more than a few will likely

end up on the roadside too. Pack a toolkit to at least handle the basics.

For bigger trips it makes sense to pack a big kit but that is not right for every person or situation. The best time to build a toolkit for your motorcycle was yesterday and the second best time is right now.

Here are six basic essentials for your travel toolkit.

Screwdrivers

Many bikes are assembled with slotted and Phillips-head screws, and even a precursory inspection often requires removing an access panel or cover. Sometimes a noise or vibration does



not indicate immediate death for your bike or engine, and after inspection you can determine if it is safe to carry on your way despite some part or piece misbehaving. A screwdriver can also act as a stethoscope in

a pinch too, allowing you to track down a goofy noise for better diagnostics with less disassembly.



Pliers

The cutting edges in these can be used as wire strippers or even cutting small hoses.

Whether you need to deal with a stubborn spring hose clamp or

moving a piece that got a little hot, pliers are the tool for the job. At bare minimum you should carry needle nose and slip joint pliers, as these will cover the vast majority of tasks on the roadside. Bonus points if your needle nose pliers have a cutting edge, as this will work for wiring repairs or stripping.

Sockets and wrenches

It's hard to take anything apart or service pieces without the ability to remove nuts and bolts. If you are handy and want to carry



the bare minimum carry your manufacturer's tool kit supplemented by some of the tools in this article.

Be very careful to check your bike for both metric and SAE sized fasteners. Today's bikes have both. If in doubt, grab a full set of both SAE and metric, because you never know what modifications someone previously made with mixed hardware. This also gives you the chance to be the hero in someone else's story when you have the tool they need in order get home.



Oil Spots, , Continued...

Fluids

Carry the fluids that you're most likely to lose so you can still safely refill and continue your ride. Some folks will tell you to carry brake fluid, but if you're losing brake fluid, that's not something to top off and continue. Your brakes are a critical safety system that should be repaired properly by a pro. Your roadside assistance insurance is going to be the best tool to use if the brakes go bad while on the road.



Jump Pack

Batteries go flat. It just happens sometimes, especially on motorcycle electrical

systems in which small draws can go unnoticed until its too late. A jump pack can provide the juice to get your engine running again or keep it running in a real pinch. Also, most jump packs these days are small and light, while also packing more punch than ever. A bonus is it allows you to charge your phone or other critical accessories if you find yourself stranded and waiting for a tow.



Bonus: Tool roll

A simple tool roll is cheap and allows you to keep all your trip-saving bits and pieces together. Tuck it all way back in

the saddlebag and rest easy each time you take the

bike out knowing that you've got at least the bare minimum needed to keep your trip on the road rather than the shoulder.

Motorcycle Tire Info

We know that they are usually round, usually filled with air or nitrogen and usually expensive. But how familiar are we with the different tire compounds and their effect on our riding comfort and safety?



We know that they are usually round, usually filled with air or nitrogen and usually expensive. But how familiar are we with the different tire compounds and their effect on our riding comfort and safety?

MATERIALS AND TREAD DESIGN

While automotive and motorcycle tires serve the same basic function — supporting and cushioning the wheels of a vehicle — they have very different makeups, since their nuanced purposes differ.

Motorcycle tires are designed to generate cornering forces when they lean, so the construction is not always the same from the center out to the shoulder. The design and construction approaches are very different from other vehicle tires.

The makeup of a motorcycle tire affects how it grips surfaces, handles cornering, sheds moisture and enhances mileage, and manufacturers are continually conducting research and testing to broaden the performance ranges of their products as well as the scope of conditions in which riders can use them. Anything from tread compound changes, small crown profile changes and even subtle tread pattern changes can have a dramatic effect on how a tire handles a certain type of terrain.

Grip is perhaps the easiest aspect of tires to understand, because we can actually feel it. Tread depth determines how well a tire can grip a surface. The deeper the tread, the better grip a tire has on rough, uneven surfaces.

(Continued on pg 6)

Oil Spots, continued...

Tread patterns play an equally important role in a tire's grip. Tread patterns dictate how water will flow off a tire. Motorcycle tires often use a specific tread pattern that ensures consistent performance across various surfaces as well as the effective channeling of water away from the center of the tire.

When designing and selecting tread patterns, manufacturers must first consider the performance targets that have been set for the tire.

The type of rubber used in a tire will affect both its mileage and grip. Furthermore, perhaps contrary to popular belief, it's not just one type of rubber being used across the whole tire — it's a complex blend of different rubbers, both natural and synthetic.

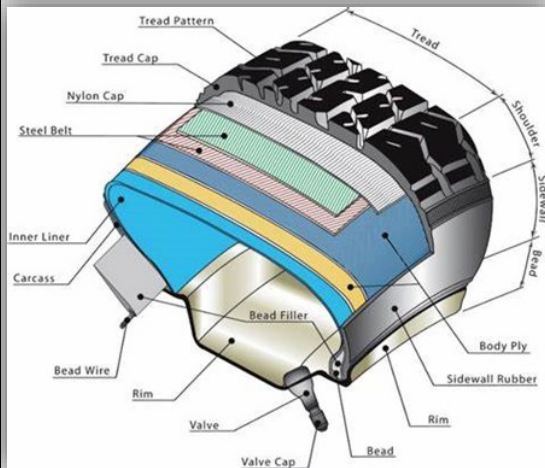

For example, a tire may feature three different rubber compounds across five different zones: The compound in the center of the tire is designed for higher mileage, whereas the compound on the shoulders of the tire is designed for maximum grip. When combined, the tire achieves an optimal mix of mileage and performance.

Tire manufacturers invest a lot of time, research and development to ensure that motorcycle tires are optimized for various applications. This means certain rubber compounds (e.g. full silica) are specifically developed and incorporated into tires in strategic amounts and locations to get the highest level of performance out of the tire.

Of course, it's not just the makeup of the tire that affects its performance and life. The type of riding one does in addition to how one maintains the tires are critical factors as well.

Tires blend into the background when customers look at bikes. They tend to take a backseat on the maintenance list for owners as well. There's one area in

which motorcycle riders fall short in terms of motorcycle maintenance, maintaining the proper air pressure in tires.

It's such a simple maintenance fix, and yet all the experts agree that low tire pressure is one of the biggest issues they come across. Brian



Davenport, senior sales manager for Metzeler, notes, "I would estimate around 70% of the motorcycles on the road today are not running the proper air pressure. The lowest bike I checked at the Sturgis Rally this year had 18 psi in the front and 21 psi in the rear. Proper inflation should have been 38 psi in the front and 45 psi in the rear. The rider didn't even notice how low the tires were."

Proper tire pressure is not set by the tire manufacturer — it's set by the bike manufacturer. The recommended cold tire inflation pressure is usually found on the swing arm and/or owner's manual. This should be checked often, as tires can lose upwards of 1 to 2 psi a month.

Riding habits and tire pressure are the most important aspects to determining the life of a tire. For instance a race tire may last only a few laps during a road race, whereas a touring tire could potentially travel for thousands of miles.

The lifespan of the tire is largely determined based on the type of riding and proper tire maintenance, specifically tire pressure. With the proper tire pressure and regular riding, your tires should last thousands of miles.

And while riders might be tempted to put some brand-new tires to the test as soon as they're outfitted on the bike, you'll want to hit the brakes on that idea. Some riders don't realize that there is a scrub-in/run-in period for new tires. Basically, tires need time to break in and scrub off any mold release agent from manufacturing, and riders need that time to adjust to the new tires. Riders should ride slowly and carefully for the first 60 miles until you become accustomed to the performance of your new tires.

(Continued on page 7)



Oil Spots, continued...

Avoid extreme maneuvers, including sudden acceleration, maximum braking and hard cornering, until you have become accustomed to the performance of your new tires.

And, there is another important part of part of maintenance, cleaning. Luckily, keeping tires dirt-free doesn't require any special chemicals. Harsh cleaning, chemicals are discouraged.

When cleaning tires, riders should only use soap and water with a soft brush. Never put a conditioner or 'tire shine' on the sidewall or anything of that nature. Stay away from all petroleum-based products and harsh cleaners, since they could affect performance or damage the tire.



Jessi CombsFacebook/Jessi Combs

[Jessi Combs' Fastest Woman on Earth documentary](#)

The Fastest Woman on Earth is an HBO Max documentary about Jessi Combs, who, among other things, went after land speed records in a jet airplane-turned-car called the North American Eagle Supersonic Speed Challenger, a converted 52,000-horsepower F-104, ground-bound by the removal of its wings.

On August 27, 2019, Combs was killed in a crash at the 13-mile Alvord Desert dry lakebed in Southeast Oregon when there was a failure in the front wheel assembly. She was a popular figure on television, driving a Bugatti on Jay Leno's Garage, and hosting the All Girls Garage, Mythbusters and Overhaulin' TV series.



A talented fabricator and racer, Combs won a lot of off-road races. Her jet car was viewed by some racers as particularly dangerous, which turned out to be true. "I'm not afraid of dying,"

she says in the documentary, "but I'm not ready to die. It's not as glamorous as it seems. If you're chasing adventures, you're going to sacrifice having a relationship. I can't have a family and try to break a land speed record." Jessi Combs was 39.

Combs lived life on her terms, and The Fastest Woman on Earth should be an inspiring film. She was awarded the Guinness record for going 522.783 mph before her crash. It began streaming on HBO Max October 20.

[KTM 890 Adventure R features a new low](#)



KTM

KTM has announced a new "demo mode" that will activate all the technological features offered on 890

Adventure R for the first 932 miles. After that point, riders will have to buy any feature that they want to keep on the bike for the ensuing miles. KTM says that demo mode is a way to allow riders to try features like the traction control, cornering ABS, or other rider modes tuned for various terrains and know exactly what they are getting and whether or not such a feature would make sense to have on their bike before plunking down unnecessary lumps of cash.

On the other hand, this really looks like the base MSRP includes these features only to have them taken away by a line of code after a few months of ownership. All the hardware is there, and it is clearly functioning, so neutering the bike shortly into ownership is easily perceived as a money grab similar to the old drug dealer "first hit is free" concept.

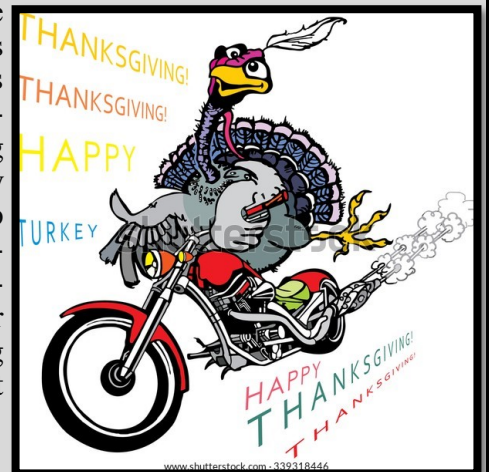



The Road Not Taken...

Robert Frost's "The Road Not Taken" is a poem where a narrator describes their solitary walk in the woods and the choices used to decide what path to take and those choices repercussions.

Instead of walking in the woods, imagine the motorcyclist who has many choices in their ride, the wanderlust of motorcycling and always longing for the "the road not taken."

*Two roads diverged in a yellow wood,
And sorry I could not travel both
And be one traveler, long I stood
And looked down one as far as I could
To where it bent in the undergrowth;*

Then took the other, as just as fair,

*And having perhaps the better claim,
Because it was grassy and wanted wear;
Though as for that the passing there
Had worn them really about the same,*

*And both that morning equally lay
In leaves no step had trodden black.
Oh, I kept the first for another day!
Yet knowing how way leads on to way,
I doubted if I should ever come back.*

*I shall be telling this with a sigh
Somewhere ages and ages hence:
Two roads diverged in a wood, and I—
I took the one less traveled by,
And that has made all the difference*

*Enjoy the journeys!
Anonymous Top Cat*

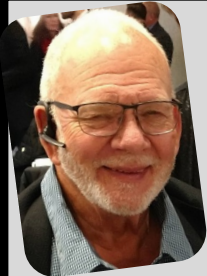

My Riding Career!

VP's Vision

Well, we all have our stories, so here is mine... When I was 3 or 4 years old all I wanted was a tri-cycle. For a celebration (can not remember which one) I got a hand me down. For my 7th birthday I got another hand me down a

one speed bicycle that was so big we had to add blocks to the peddles so I could ride it. When I stopped, I had to lean it way over to get off it.

My next used acquisition was a three speed with hand brakes. It served me well for delivering newspapers on first, one paper route and then, my second and additional paper route. Next was a fifteen-speed mountain bike. Then it was muscle cars.

When I moved to Lake Zurich, all the neighborhood teens were riding dirt bikes. My friend Vinnie, who hated motorcycles, had a friend who owned an enduro that was 175cc suggested I buy it for \$400 and ride with the teens. So, I did for several years. Then I decided it was time to go to the street, so I bought a used Honda Shadow 700cc six-speed. Got a permit and almost immediately my M endorsement. Rode for six years and about 25,000 miles. Used it a lot as a commuter vehicle.

Then it was time for my first Harley-Davidson. A 1997 Ultra. I bought it New (my first new and my first Harley-Davidson). Rode it for 4 years and about 40,000 miles. I found myself being left behind riding from Hewitt to Sturgis. So I bought a 2001 Road Glide Screaming' Eagle in order to keep up with the group. Since then, I have ridden it about 28,000 miles local.

Now because I renewed my driver's license at age 75 in October, I could not renew my M endorsement. So, I had to get a riding permit. Back to the beginning of my street riding days. And it appears the earliest I can get my M endorsement is the spring of 2023. More news to come as I progress to get back to real riding. Next month, I'll tell you how to avoid being in this position!

Sincerely your VP,
Ric Case

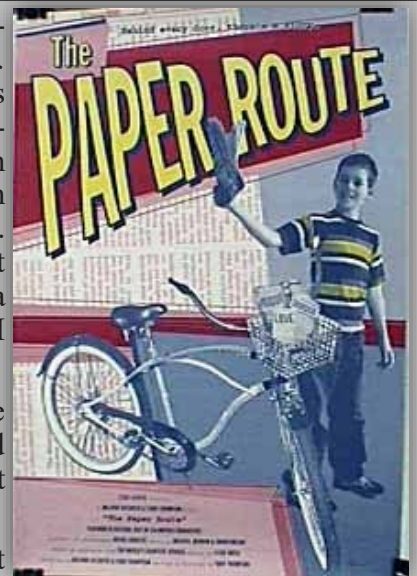



Harley-Davidson recalls 200,000 Trikes and Touring Motorcycles...

**The motorcycles may experience unintended brake illumination
James Limbach**



Photo source: Harley Davidson.

HDMC is recalling 199,419 of the following model year 2019-2022 Trikes & CVO Trikes, and model year 2020-2022 Touring & CVO Touring motorcycles: The brake lights may illuminate without the rider applying the brakes. Unintended illumination of the brake lights may confuse other drivers, increasing the risk of a crash.

What to do

Dealers will update the software on Touring and CVO Touring motorcycles.

On Trike and CVO Trike motorcycles, a new pressure switch will also be installed.

All repairs will be performed free of charge.

Owner notification letters are expected to be mailed October 26, 2022.

Owners may contact Harley-Davidson customer service at (800) 258-2464. Harley-Davidson's number for this recall is 0635.



MAKE	MODEL	YEAR
HARLEY-DAVIDSON	FLH	2021
HARLEY-DAVIDSON	FLHP	2020-2022
HARLEY-DAVIDSON	FLHR	2020-2022
HARLEY-DAVIDSON	FLHRXS	2020-2022
HARLEY-DAVIDSON	FLHT	2020-2022
HARLEY-DAVIDSON	FLHTCUTG	2019-2022
HARLEY-DAVIDSON	FLHTCUTGSE	2020-2022
HARLEY-DAVIDSON	FLHTK	2020-2022
HARLEY-DAVIDSON	FLHTK SHRINE	2021-2022
HARLEY-DAVIDSON	FLHTKSE	2020-2021
HARLEY-DAVIDSON	FLHX	2020-2022
HARLEY-DAVIDSON	FLHXS	2020-2022
HARLEY-DAVIDSON	FLHXSE	2020-2022
HARLEY-DAVIDSON	FLHXST	2022
HARLEY-DAVIDSON	FLRT	2019-2022
HARLEY-DAVIDSON	FLTRK	2020-2022
HARLEY-DAVIDSON	FLTRKSE	2022
HARLEY-DAVIDSON	FLTRX	2020-2022
HARLEY-DAVIDSON	FLTRXS	2020-2022
HARLEY-DAVIDSON	FLTRXSE	2020-2022
HARLEY-DAVIDSON	FLTRXST	2022



General Membership Meeting Minutes September 6th,

Respectfully Submitted
by: Diana Lanute

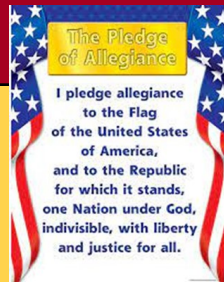

President's Section: Gene Rigsby

- ◆ 7:00 pm, Meeting called to order
- ◆ Pledge of Allegiance
- ◆ Guests – Introductions
- ◆ Announcements
 - Tom Malia – 10/2
 - Lonnie and Rick Agrimonti Anniversary– 10/10
 - Bozena Hasztrakiewicz – 10/11
 - Andy and Bozena Hasztrakiewicz – 10/18
 - Rick Agrimonti – 10/12
 - Ric Case – 10/22 *Victoria Well – 10/22
 - Jackie and Ric Case Anniversary – 10/25
 - Gene Rigsby – 10/30

V.P.: Ric Case

- ◆ Ric reviewed his story on dehydration. See the October ROAR for the full story.

Past President: Wayne Kirkpatrick

- ◆ Wayne cautioned everyone to be careful coming through downtown Barrington. The roads are not completed, and the manhole covers have about a 4" lip. It is dangerous for cars, but these situations can be very dangerous for motorcycles. Be aware!

Treasurer: Don DeLoro

- ◆ Don will be sending out the invoices for the 2023 membership dues. Please return them with payment ASAP so that you will be a member in good standing and be able to vote in the next election.

Safety: Mike Bradbury

- ◆ Accident/safety review – Mike Bradbury
 - Nothing to report at this time. The season is coming to a close...
- ◆ Kaution Korner – Gene Rigsby
 - Gene did a review of his article in the October ROAR. See the publication for all details.
- ◆ Kaution Korner preview – Mike Bradbury
 - Mike previewed the article he will be writing for November. He presented data from a 2017 study on the benefits of wearing a helmet. The details will be in the next ROAR.

Safety Video: Mike Bradbury

- ◆ **Motorcycle Airbags Exist - But No One Uses Them?:**
<https://youtu.be/N2jZryt607U>
Technical difficulties prevented the movie from being shown. Watch when you have time!

Membership: Ted Makarewicz (Abs)

- ◆ No presentation of New member intro/welcome packages
- ◆ Membership drive ideas?? If you have any suggestions forward them to Ted.

Activities: Rick Agrimonte / Greg Smith

Recent activities

- 9/25 – Potosi Brewery ride - Mailia

Future activities

- ◆ 10/15 – Haunted Picnic – Gene Rigsby. The information is on the website and food will be provided by Noelle Rigsby!
- ◆ 10/23 - GRASS – Mike Bradbury – be sure to attend if you need to remain a member in good standing and... YOU WILL BE SAFER on your bike after attending this class!
- ◆ Emil Kornecki spoke of a trip that he took recently and gave the group the details. Sounds like a great opportunity for a future activities:
- ◆ Tug-o-War across the Mississippi. LeClaire, Iowa and Port Byron, Illinois save their 4th of July funds for this event and it is very spectacular. Fireworks, tug-o-war for all ages AND a Tug boat Tug-o-War! Mid-August Dates are announced early in the year! Lets plan for 2023! [Port Byron Tug Fest...](http://PortByronTugFest.org) Tugfest.org.
- ◆ Rock Island Grand Prix. A Go-Cart Race that the whole area gets behind! Sounds like another option for the 2023 year. It is on Labor Day Weekend, but one afternoon would still allow time for family gatherings too! [Rock Island Grand Prix \(racerockisland.info\)](http://RockIslandGrandPrix.com)

Charity: Rich Lanute

Rich reported that the committee will meet soon and identified June 11, 2023 as the next Ride for Dream Date. Discussion on the venue will continue, but at this time VOLO is still the site.

Mary Kirkpatrick reminded the group that the annual Fashion Show Fundraiser, which is NISRA's largest event each year will be held on November 19th, 2022. Rich will bring this up at the board meeting next Tuesday and Gene said that at that time we can make the decision on what the Club will do in support of purchasing a table.

Products: Ted Makarewicz (Abs)

Get your gear now!!

50/50 Raffle: Andy Hasztrakiewicz had David Ramirez pull the 50/50 ticket and Ric Case was the winner. \$80 was added to the charity account.

Meeting Adjourned by Gene Rigsby at 7:40.



BOARD MEETING MINUTES SEPTEMBER 13TH, 2022

Respectfully Submitted
by: Diana Lanute

President's Section: Gene Rigsby

- ◆ Meeting called to order at 7:00pm
- ◆ Emails / Articles need attention – None.
- ◆ Immediate needs? – None.

Past President: Wayne Kirkpatrick

- ◆ Open discussion – Mary thanked everyone for getting ROAR articles in on time!

Vice President: Ric Case

- ◆ Open discussion - None.

Treasury: Don DeLordo

Report/review –

- ◆ Purchases made by Wayne for 2 flag stands and Don purchased office supplies.
- ◆ Top Cat membership dues – Bill for yearly membership going out and is due by election/voting date of 11/6.
- ◆ Any member who joined after October 1st has their membership carry over to the following year.
- ◆ Don noted that TC subsidized \$20 on \$50 tickets last year. TC will subsidize \$200 on a table for NISRA this year.
- ◆ Gene talked about our club waivers which are sent out every year to members and stated nothing has changed in the waiver this year.
- ◆ Mike Bradbury – Regarding G.R.A.S.S. class, he has all supplies he needs for this class.

Activities: Greg Smith

Future Events

- ◆ Calendar review - Oct/Nov, etc.
- ◆ 10/15 - Haunted picnic ride - Rigsby's – Weather looks good!
- ◆ 10/23 - G.R.A.S.S. – Bradbury – Gene will be teaching this class.
 - Wayne added – We should have a second person (second set of eyes) to aid in the class so nothing is overlooked or missed!
- ◆ 12/4 – Toys 4 Tots – See Ted.
- ◆ No date – Potosi Brewery Ride, if weather is good – See Tom Malia.

Safety/RC: Mike Bradbury

- ◆ RC activity ideas – Get notice up early so people can plan to attend.

Membership/Products: Ted Makarewicz

- ◆ New member application – Motion made and approved by the Board requiring applicants to attend 2 events, or 1 event and a ride, before the Board reviews application.
- ◆ We have 9 new members.
- ◆ New member mentor - Assign mentors
- ◆ Membership drive ideas? Doing okay with Facebook.
- ◆ Product needs? We are out of L black and SS TC tee shirts. Will purchase 6 at \$18 each.
- ◆ Product payment

Charity: Rich Lanute

- ◆ Ride for Dreams – Rich discussed the decline in event participation for this event. Discussion held regarding ways to generate money for NISRA, and looking at ways to get more people involved. Proposal made for next meeting to collect ideas and get membership participation. Rich to speak at next meeting regarding member donations.
- ◆ Notations by Rich – Last year we had 19 participants in this charity ride. In the last 3 years the ride generated the following amounts –
 - 2020 - We cleared \$528 without donations.
 - 2021 - We cleared \$174 without donations.
 - 2022 - We cleared \$72.32 without donations.

Secretary: Diana Lanute

- ◆ Approval of proposal to send minutes to all Board members for any comments before Mary adds report to the ROAR.

Additional Notes:

- ◆ Wayne discussed the Board Slate –
- ◆ Nov 6 - Due date for members to pay dues.
- ◆ To vote – Must be a member for one year; attend 5 TC events with G.R.A.S.S. class within one year.
- ◆ Dues current before Nov 6 (election time).
- ◆ Wayne also discussed the status of our 39 members and their fulfillment of member requirements to be eligible to vote.

Meeting Adjourned at 8:40 by Gene Rigsby, President

Gifts to think about for the Holidays coming up...



Personalized Bobble Head.
<https://www.dolls2u.com/motorcycle-rider-p-15615.html>

1. Upload or email your pictures
 2. Select the options
 3. Confirm your order
- Prices Vary!

Etsy... \$13.95



Beer Barrell \$155 or
Brandy Decanter \$79 - Amazon



Tire Tread Ring
Motoloot.com
\$39.99

Motorcycle Bike wing Ring
BikeChainJewelry.com
\$23.00



November Birthdays and Anniversaries!



5 Mike Bradbury
7 Andy Hay
16 Mark Sullivan
26 Christine Sullivan

Happy Days to our Top Cats Celebrities for November!!
Let us know your special dates so that we can celebrate with you!

20 Rich and Diana Lanute



Top Cats Buy, Sell, Trade....
The best way to ensure good quality at fair prices!

GREAT DEALS!



Put your items here and get the word out that you have stuff to sell!



TOP CATS BUSINESS MART

BUSINESSES OWNED AND/OR MANAGED BY TOP CATS MEMBERS

kw SUCCESS
REALTY

KELLERWILLIAMS.

**Mary
Kirkpatrick**

Realtor

262-344-6228

e: marykirkpatrick@kw.com

w: MaryKirkpatrick.kw.com



600 Hart Road, Suite 105
Barrington Illinois 60010



Each Office Is Independently Owned and Operated

600 Hart Road, Suite 105
Barrington Illinois 60010



Each Office Is Independently Owned and Operated



*Network with your fellow
Riders here...*

And Be Thankful!



Support the TOP CATS Patrons



Doug Jackson and Staff Support our Top Cat's Ride for Dreams!



PALATINE, IL

Home to Alley 64,
Top Cat's Monthly Meeting Spot!

Membership Has Its Privileges!

GRASS Classes are held at the Keller -Williams Offices!

Thanks, Greg for supporting our Top Cat's Safety Class!

All suppliers and vendors who support the Top Cats by providing discounts to Top Cats members will be listed in ROAR.

Sign-up your favorite merchant today!



Greg Smith

**Keller -
Williams
Success
Realty**

**600 Hart Rd.
Suite 105
Barrington, IL
60010**

847.870.0957

Have one of our own Top Cats work with you to buy or sell your home!

NISRA Families have so many wonderful opportunities because of the NISRA staff... Can we find ways to continue to help them?





RIDES & EVENTS

Date	Ride/Event	Location	Destination	Time	Leader
Tuesday, November 1st	General Meeting	Palatine	Alley 64	7:00 pm	Rigsby
Tuesday, November 8th	Board Meeting	Palatine	Alley 64	7:00 pm	Rigsby
Tuesday, December 6th	General Meeting	Palatine	Alley 64	7:00 pm	Rigsby
Tuesday, December 13th	Board Meeting	Palatine	Alley 64	7:00 pm	Rigsby
IDEAS?	Talk to	Greg or Rick	And get them	On the	Calendar!

All ride and event information along with the Photo Gallery can be found at
www.TopCats.org.



Barrington Library

Location and Hours
505 N. Northwest Highway
Barrington, IL 60010

847-382-1300
balibrary.org

See the Top Cats Archive

**FREE ADVERTISING in ROAR for
TOP CATS Business Owners**

Attention all Top Cats business owners!

As part of our ongoing philosophy to support our members and goal to provide a more value-rich publication, we are now offering free advertising space in ROAR for Top Cats business owners. Each business owner can submit advertising content and graphics up to 2 X 3.5 inches (Business Card size) for their company.

We will run the ad for 3 months after which you will need to resubmit it.
This offer is for Top Cats business owners only. We are not accepting advertising for other businesses at this time.

Submit your ad along with contact information to the ROAR editors at ROAR@TOPCATS.org



ROAR



TOP CATS OF ILLINOIS is a group of motorcycle enthusiasts with similar interests. Members consist of responsible Leaders, Presidents, Chairmen, Owners, Proprietors, Partners, principals, CEO's, and other 'Top Cats' of large, medium and small organizations, institutions, and companies.

For more information about the Top Cats visit our website at www.TopCats.org

ELECTED OFFICERS & DIRECTORS		COMMITTEE LEADERS		ROAR	
President	Gene Rigsby- gene.rigsby@gmail.com	Activities	Greg Smith GregSmith@kw.com	Executive Editor & Board Liaison	Mary Kirkpatrick Mawalters57@gmail.com
Vice President	Ric Case Riccase@Comcast.net	Archives	Open	Editor-in-Chief	Mary Kirkpatrick mawalters57@gmail.com
Treasurer	Don DeLordo Don_De@att.net	Charity	Mary Kirkpatrick Mawalters57@gmail.com	Publisher	Open
Secretary	Diana Lanute Diana.Lanute@att.net	Membership	Ted Makarewicz Hogski@hotmail.com	ASSOCIATE EDITORS	
Past President	Wayne Kirkpatrick wkirkpa177@aol.com	Awards	Mike Bradbury bradbundy@comcast.net	Executive & Board	Wayne Kirkpatrick wkirkpa177@aol.com
Director	Rich Lanute Richard.Lanute@att.net	Safety	Mike Bradbury bradbundy@comcast.net	Safety & Road Captains	Mike Bradbury bradbundy@comcast.net
Director	Greg Smith GregSmith@kw.com	Website	Mary Kirkpatrick mawalters57@gmail.com	Membership	Ted Makarewicz Hogski@hotmail.com
Director	Mike Bradbury bradbundy@comcast.net	Products	Ted Makarewicz Hogski@hotmail.com	Charity	Mary Kirkpatrick Mawalters57@gmail.com
Director	Ted Makarewicz Hogski@hotmail.com	SGT at Arms	Andy Haszlakiewicz andyh9946@gmail.com	Events & Calendar	Greg Smith GregSmith@kw.com & Rick Agrimonti Rickandyolie@att.net
Founder	Carl 'Virgo' Bender 1941-2001			Motorcycle Community	Wayne Kirkpatrick wkirkpa177@aol.com

© Copyright 2010 **TOP CATS OF ILLINOIS**

ROAR is the official publication of the **TOP CATS OF ILLINOIS**

and is published on the 1st of each month.

The content and opinions expressed in articles are those of the authors and not necessarily those of **TOP CATS OF ILLINOIS**

For questions or to submit comments or articles for publication, contact the editors at

ROAR@TopCats.org