



ROAR

June, 2023

Volume 23, Issue 6

Inside This Issue

PRESIDENT'S POINT	2
KAUTION KORNER	2
Oil Spots	4
VP's Vision	8
NISRA	9
RIDE PREVIEW!	10
GENERAL MEETING	12
BOARD MEETING	13
GRASS Schedule	14
Celebrations!	14
Business Mart	15
Top Cats Patrons	16
Rides and Events	17
TC Organization	18

The Pick-Up Picnic Ride!
 We are able to Post Ride Pictures!
 Yes! We are Riding!



Upcoming Events

- JUNE**
- 2-4 DOOR COUNTY!
 - 6 GENERAL MEETING
 - 11 RIDE, ROCK, RUMBLE!
 - 13 BOARD MEETING
- JULY**
- 1-3 TREMPLEAU
 - 11 GENERAL MEETING
 - 8-9 I WOULD RIDE 500 MILES
 - 22 GRASS CLASS
 - 30 LEAVE FOR STURGIS!

The Official
 Publication
 Of Top Cats
 Illinois

Talk to Greg Smith and
 Rick Agrimonti and get
 your ideas on the
 calendar!





ROAR

PRESIDENT'S POINT

And Now a Word from your President...



Hello Top Cats!!

Welcome to the official riding season!!!

I hope you and your family are doing well, sharing some time together, enjoying the great weather and remembering those gone but not forgotten over the Memorial Day weekend.

Speaking of the Memorial Day weekend, I had the pleasure of riding out to Potosi WI, with a fine group of our club family, all lead by Tom Malia. Great weather, roads, food and company. Thanks Tom, and all who attended and made it a great experience.

I also held the annual President's Progressive Pickup Picnic Ride.... The weather turned out great and all had a great time.

Some great rides are coming up in June, Like the Door County Ride, lead by Mary and Greg and the Route 66 Museum ride lead by Don. Check the club calendar for details.

REMINDER.... Our charity event is quickly approaching. **PLEASE** attend and bring a friend or 2.... The Ride, Rock, Rumble (previously known as the Ride for Dreams) is on June 11th starting out at WSHD. Details are in the Top Cats calendar.

As usual, watch for blasts and check the Top Cats event calendar regularly and by all means **SAVE THE DATES first**. Don't forget to get any activity or ride ideas to Rick Agrimonti or Greg Smith.

As always, please feel free to reach out to me at any time via my email: Gene.rigsby@gmail.com, or phone, 847-770-9425.

Looking forward to seeing you there.... Gene "Lucky" Rigsby

KAUTION KORNER



Things to SEE and Avoid..

By: Wayne 'Traveler' Kirkpatrick
Sr. Road Captain and Past President of Top Cats Illinois!

This is the time of the year spring weather changes to summer and motorcyclists take to the road in large numbers. Animals small and large take to the roads also and become an increasing hazard again until late fall. You will find that taking the time to do your pre-ride risk assessment will pay off in safe cycling throughout the year.



Not only does a rider look at the weather, cycle, and the route. The animals the rider could encounter should also be considered. These are some basic tips for avoiding the animal that could injure or kill you while cruising through the countryside.

- ◆ First and foremost, you should always wear approved safety gear; Helmet (Full-face is the best), gloves, long pants, brightly colored long-sleeve shirt/jacket (day), retro reflective upper-outer garment (night), over the ankle shoes (leather boots are the best), and any other ballistic type outer wear that protects your body.

(Continued on Pg 3)



Kaution Korner, Continued

- ◆ Heed deer-crossing signs, particularly in the seasons and times of day when deer are active. Slow down, use your high beam, and cover the brakes.
- ◆ Additional good, powerful driving lights are worth their weight in gold on a deserted road at night. Alternatively, fit a 100 – watt bulb as your high-beam.
- ◆ Flashing your headlights may break the spell that seems to cause deer to freeze.
- ◆ Revving your engine is a foreign sound to animals that may trigger their “Flight” mode. It sounds strangely close to a loud growl to them.
- ◆ If you are driving at night and see the oncoming headlights “twinkle”, that is probably a moose or a deer intersecting the headlight beams. They are rarely alone and may be with young. Slow down and keep your eyes open.
- ◆ During the springtime, deer are attracted to the side of roads to lick the salt applied during the winter months to control iced roads.
- ◆ Watch for dips in a road where the surrounding land is wet, or a brook may cross under the road. These are usually trails used by animals. Transportation departments label some animal crossings.
- ◆ “S.E.E.”- [Search, Evaluate, and Execute](#) a simple but powerful strategy taught in the Basic Riders Course (BRC). It should be employed as far in



front of the rider as visibly possible when riding in areas where deer are common. The strategy will

allow more time to stop if a deer is spotted. Stopping is the only appropriate maneuver to avoid a deer strike. Once the deer is spotted and the motorcycle comes to a stop the rider can proceed very slowly with caution. Again, making noise to scare their buddies away.

- ◆ Small animal motorcycle collisions with raccoons, possums and the like can also be deadly. A fast-moving motorcycle with the brakes locked is a recipe for disaster. A glancing hit can veer a motorcycle off the road. These animals are low and have a round body structure that doesn't “crush,” causing

the body to roll under an undercarriage. The proper position in this case is important the rider should ride across a small animal as he would ride over a small, fixed obstacle.

- ◆ When negotiating a small animal hazard, slow down as much as traffic and time will permit, approaching at a 90-degree angle if possible. Avoid target fixing by looking ahead once the path over the obstacle is determined. Rise slightly off the seat before reaching the obstacle keeping the knees bent and against the tank. Shift weight to the rear by slightly rolling on the throttle just before the front wheel makes contact with the small obstacle, remembering to not pull or jerk on the handle bars but....hold on firmly. Rolling on the throttle helps reduce the weight on the front wheel helping to climb over the obstacle. Upon contact with the obstacle roll off the throttle immediately so the rear wheel is not under power when it strikes the object.
- ◆ Finally, every encounter with an animal is different. There is no “Standard” method to react to animal encounters. Do the best you can, remember your options and, if all else fails, aim for the moving animal because....it won't be there when you get there!



Be Prepared!
Don't let these situations surprise you!

Oil Spots

By Traveler



Curtiss Motorcycles New Electric



Curtiss Motorcycle Co. has announced “The 1,” its debut flagship product designed to appeal to

those looking for luxury, sustainability and EVs, the company says.



Curtiss says it has received a Notice of Allowance for its patented Axis-Centered

Design operating system that is featured on “The 1.” The company says this system makes the motorcycle completely symmetrical, “offering riders a balanced, easy, smooth ride.” This protected platform is modular, radically scalable and will be used on every future Curtiss motorcycle, the company says.

Curtiss adds that the motorcycle’s thermal management technology yields “best-in-industry efficiency with application to all forms of battery-based electrification,” according to the company.

“The 1,” is Curtiss Motorcycle’s debut flagship product designed to appeal to those looking for luxury, sustainability and EVs, the company says.

Autonomous Cars Confound First Responders

Passengers ride in an electric Jaguar I-Pace car outfitted with Waymo full self-driving technology.
Los Angeles Times via Getty Images



As police and fire officials responded to a drug lab explosion in San Francisco they had to contend with a driverless car that wandered into the middle of the scene.

Body-cam footage from February shows an officer yelling at the Waymo vehicle and tossing a flare to keep it from driving over fire hoses. Several weeks earlier, a firefighter reported having to smash the window of a driverless vehicle to make it stop approaching a fire scene. In March, firefighters said they had cordoned off a street to deal with wind damage, only to have two Cruise vehicles drive through the warning tape and become entangled in downed wires. First responders have cited at least 15 instances of a Cruise or Waymo car interfering with an emergency scene.

Hmmmm.... Let me see....they can’t see a fire truck but they’ll see a motorcycle?

Chalk this up to one more unseen obstacle autonomous cars will have to overcome.

BMW Motorrad celebrates 100 years with new R 12 nineT



The RnineT is getting a special edition to

celebrate the 100 years of BMW Motorrad. The new model is the R 12 nineT, which updates the model’s name to reflect the company’s current naming convention of including the engine size in the model name. This means it is the same 1200cc boxer twin in the frame, but this new model gets updated styling centered around a gas tank that is patterned after the BMW R32 from a century ago.

The RnineT is ten years old now and has aged wonderfully. If you like the styling, you will likely enjoy the ride. With the proper mix of old-school and new-school, expect this new R 12 nineT to age well.

(Continued on pg. 5)



Oil Spots, , Continued...

Does BMW think motorcycle steering is too simple?

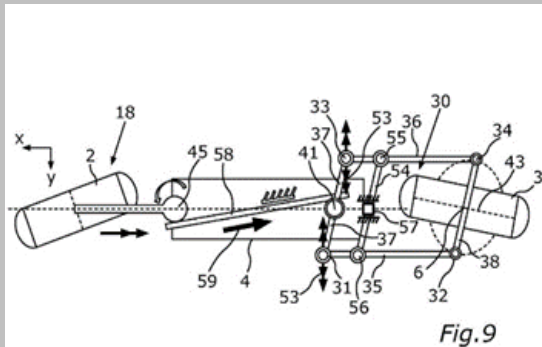

Fig. 9

BMW Motorrad

Thanks to a patent application, we now know that BMW Motorrad is at least con-

sidering a future where motorcycles steer with both wheels. The patent drawings feature a long, low, chopper-like design that is even longer and more laid out than the current R18. The designs hinge around the rear suspension and allow the rear wheel to angle in a manner that counters the front wheel. This alone signals that the design is likely targeted at low-speed maneuvers like tight parking spaces.

Patents being filed does not mean we will ever see this technology on the road. All-wheel steering is still uncommon in automobiles, where the weight and complexity are much more widely tolerated. The various designs in the patent all have additional problems to solve in order to be useful, so we are thinking this patent is just locking in the idea rather than a hint at something we will see on a production bike anytime soon. Consider this another example of the ever-evolving technology in the motorcycle community.

2023 Harley-Davidson Electra Glide Highway King

The Motor Company brings us a third member of the Icons Collection. The 2023 Harley-Davidson Electra Glide Highway King channels the 1968 FLH Electra Glide with fantastic aesthetic results.



While some observers have casually claimed the 2023 Harley-Davidson Electra Glide

Highway King is just a tarted-up Road King, it's not. H-D certainly pays homage to the Road King with the name. However, there are enough functional differences to draw a clear border between them:

- ◆ The Highway King runs a Milwaukee-Eight 114, while last year's standard Road King—absent from the lineup in 2023—was powered by a 107.
- ◆ Those are wire-spoked 16-inch wheels on the Highway King, compared to 18-inch cast aluminum wheels on the Road King. Also, the front tire model on the Highway King is a Dunlop Harley-Davidson D402F, compared to a D408F on the Road King.
- ◆ The Highway King is a solo tourer—the Road King was ready for two-up travels.
- ◆ The seat height of the solo seat on the Highway King is 31.1 inches, compared to 27.8 inches for the stepped built-for-two Road King saddle—a considerable difference.
- ◆ Rear wheel travel is reduced from three inches on the Road King to 2.15 inches on the Highway King.
- ◆ The rider triangle on the Highway King is considerably different from the Road King due to the tall seat and the positioning of the handlebar.
- ◆ A broad range of electronic rider aids are standard on the Highway King; all were options for the Road King.
- ◆ The lower half of the Highway King's windshield is tinted to match the spectacular two-tone paint. The windshield on last year's Road King was pure clear.
- ◆ There is extra chrome railing around the seat, side cases, and front fender of the Highway King, adding to the premium look.
- ◆ The standard price of the 2022 Road King was \$19,110, compared to a list of \$26,999 for the Highway King. There will be 1750 examples of the Highway King built.

The mix of stylish nostalgia and contemporary competence makes the 2023 Harley-Davidson Electra Glide Highway King an inarguably outstanding motorcycle. While the seat height is not for everyone, if you can manage 31.1 inches between your legs, you will appreciate the comfort it affords. Add impeccable styling and sweet paint, and you're rewarded with a motorcycle touring experience like no other.

(Continued on pg 6)

Oil Spots, continued...

NEW RECORD FOR MOST COUNTRIES VISITED IN 24-HOURS



A prominent motorcycle journalist has broken a world record for visiting the most amount of countries while riding a motorcycle in one 24-hour period.

Thierry Sarasyn started his ride in southern Poland, strategically chosen because of its close proximity to a significant number of countries. After a bit of ducking and diving, Thierry found himself in northern Italy, before heading north and ending his trip in the Netherlands. At the end of the trip, Thierry racked up an impressive 1,367 miles and completed the feat in just 22 hours. Making this final point all the more impressive is the fact that prior to the trip Thierry had set the goal of completing the journey, yet breaking no speed limits and no local road traffic laws. That meant he had to basically ride 1,300 miles, through different countries all with varying traffic laws, in less than 24 hours!

The bike Thierry chose for the ride was a safe bet for any looking to clock some big miles, quickly and in comfort; the Kawasaki Versys 1000. The bike was prepped by Bridgestone prior to the run with new tyres, and Motul supplied the oil and Thierry packed some extra fuel just in case he was caught short. Oh, he also had along a mixture of Imodium, Isotonic drinks and astronaut food got him through his 22-hour marathon.

Harley-Davidson's Middleweight X440



Back in March, Harley-Davidson/Hero Motocorp X350 broke cover as a heavier-than-necessary roadster with a decidedly non-Harley-esque, 353cc parallel twin heart and a totally different angle on the markets than its spotlight sibling, the X500.

Now, Harley and Hero are aiming for the middle of the cc-laden ladder in hopes of competing against the

likes of Royal Enfield's Classic 350/Meteor 350.

Their answer to the big-boned, neutered X350? A renewed punt of air/oil-cooled power and all-American styling drawn from Harley's Nightster.

Harley-Davidson/Hero's X440 follows a more cruiser-esque aesthetic than the X350, with alloy wheels showing off 17" in measurement for the front, and an 18" unit for the back.

For exhaust systems, we've got a single-pipe number, poofing out proof of an estimated 33 ponies.

On electronics, there is a nice-sized TFT screen, which could very well afford Bluetooth connectivity, as well as a round headlight, streamlined fins, a flat handlebar and footpegs positioned beneath the riders' knees.

Apart from this, we've got USD forks, single-disc Bybre brakes, and the addition of dual-channel ABS – all with an estimated price tag of around \$3400 USD.

Outlaw Motorcycle Gangs vs. Motorcycle Clubs



According to the Department of Justice, an Outlaw Motorcycle Gang, also known as "OMG," are organizations whose members use their motorcycle clubs as pathways for criminal enterprises. OMGs are criminal organizations whose members engage in criminal activities, which include:

*Violent crime *Weapons trafficking *Drug trafficking

Motorcycle clubs are not involved in gang-related activities and crime. Motorcycle clubs consist of individuals whose activities and interests involve motorcycles only. Motorcycle clubs often include bikers who possess similar models of motorcycles.

Public safety expert weighs in on differences between Motorcycle gangs and Motorcycle clubs.

According to public safety expert Paul Szych, motorcycle clubs stay clear of drama and prefer to have a good time.

"You're going to have people that are considered to be in a motorcycle gang involved in criminal activity, but you can also have people in a motorcycle club that are not involved in criminal activity," Szych said. "They're not there to do anything except ride and hang out with their friends, their clique, their group. Members are not going to be engaged in criminal activity."

"Some just want to belong to a group. It's like an extended family to them. In all fairness, to stereotype all of them is dangerous. It's just not appropriate," Szych added.



**Potosi! A success!
So Sad if You Missed It!!**



**Pic-Nic Pick-up!
A Success!**



What beautiful Weather and Good Company for these rides! If you weren't there... you were missed! Lets fill the rest of this summer's rides with ALL of our faces!



OUR BIG DAY....

V.P.'s Vision



No, Not a birthday or anniversary—well a bit of an anniversary, IT'S OUR 26th annual Charity Ride!

Rebranded as **Ride Rock Rumble**, we are working to reach those who will enjoy the Volo Auto Museum Destination! The 10 day forecast has a high of 76* with a slight chance of rain later in the day. Could we ask for anything better??

NISRA has been part of the Top Cat Family for decades and we are looking to make this a banner year. A new start with many good 'draws'. The Bike Show, the Cars at VAM, the drawing, The Top Cats, and most importantly...NISRA. Let's make this happen!

A quick review of the memories of the Charity Ride include the following:



VAM was the destination for many years in the past. Local Boy Scout Troops did the parking. They had a band and food vendors with a picnic area and a Massage table!



Auctions, both live and silent, were included.

Many bikes from a variety of clubs in the area were in attendance!

Let's get everyone working on making this a good year for our Charity Ride! And... if you liked any of these ideas, join the Committee and let's start planning next year!

NISRA — enriching the lives of people with disabilities through meaningful recreation experiences.

All proceeds benefit: nira.org

NISRA
Northern Illinois
Special Recreation Association

TOPCATS.org

26th Annual

TOP CATS ILLINOIS

Ride Rock Rumble

June 11, 2023

\$25 per Bike • \$5 per Passenger

Includes: pre-ride coffee & pastries and entitles the ticket holder to purchase a ticket at 1/2 price for \$10.00 to the Volo Auto Museum and /or Jurassic Park.

Ride STARTS:
Woodstock Harley Davidson
2235 South Eastwood Dr.
Woodstock, IL 60098
woodstockharley-dav.com

- Registration 9:00 am
- Ride Brief 10:15 am
- Kick-Stands Up 10:30 am

Ride ENDS:
Volo Auto Museum
27582 Volo Village Rd.
Volo, IL 60073
volocars.com

Ride-in Bike Show!
\$10 to participate - registration at Volo Auto Museum
1st & 2nd Place Trophies in 6 Categories





Celebrating our Helping Hands, and NISRA Families!

Words by: Mary Kirkpatrick



For many years... 26 to be exact, Top Cats has worked to ensure that Northern Illinois Special Recreation Association has a place in our Annual Schedule. Why? Well, talk to one of the families and ask them what NISRA does for them. Stop by and See Jim Wiseman or Laura Cullatta to hear what they do each day. Check out the NISRA website. Attend the annual Fashion Show. Any one of these would give you a glimpse into what makes NISRA so special! The recreational activities provided by our donations are so very important to enhancing the quality of life for NISRA Families!

Look at the faces in these pictures! See the smiles that are provided by the NISRA activities. See how lives are enriched by the work that is done by all of the families, staff and supporters of NISRA.



Now that you have reflected on the goodness of this wonderful community, you may wonder what YOU can do. Top Cats has a great opportunity for you! On June 11th, 2023, we will hold our annual Charity run starting at **Woodstock Harley Davidson**. We will take a leisurely ride to **Volo Auto Museum** and use the 1/2 price tickets to enjoy the activities that VAM provides. WE NEED YOU to make this a successful event! Most of the supplies are already in place, so the day of the ride will be the key! Come early to help us set up in the parking lot at Woodstock Harley. Help us to sell 50/50 tickets, get bikes placed as they come into the lot, talk with riders about our **Ride-In Bike Show** and encourage them to enter, talk with Jim or Laura to find other ways to help during the year, pay for the ride and enjoy the roads on the way to VAM, help park bikes when they arrive, be ready to vote for the bikes in the show, No matter how you decide to participate, the most important thing you can do is to **BE THERE!** Warm your heart by warming others' hearts!

NISRA families are also invited, so this may be a chance for you to see those smiles in person!





Blue Skies... Sunshine... and Reasons to Ride!

Information from our Website: TopCats.Org

Take a look at some of the opportunities that we have to ride this summer! Check the website for details on our Road Captains and for making reservations!



Potosi, Wisconsin May 27th, 2023

This one is done! If you didn't make it, Tom took everyone on his usual ride... Excellent roads, great scenes, and a good meal! All had fun!

Door County Dreamin' June 2 - 4, 2023

Join us for 3 days of beautiful roads, a trip to Washington Island, a fish boil and a great meat market! Call Greg or Mary and come along!

Greg: 847.975.7653 or Mary: 262.344.62228

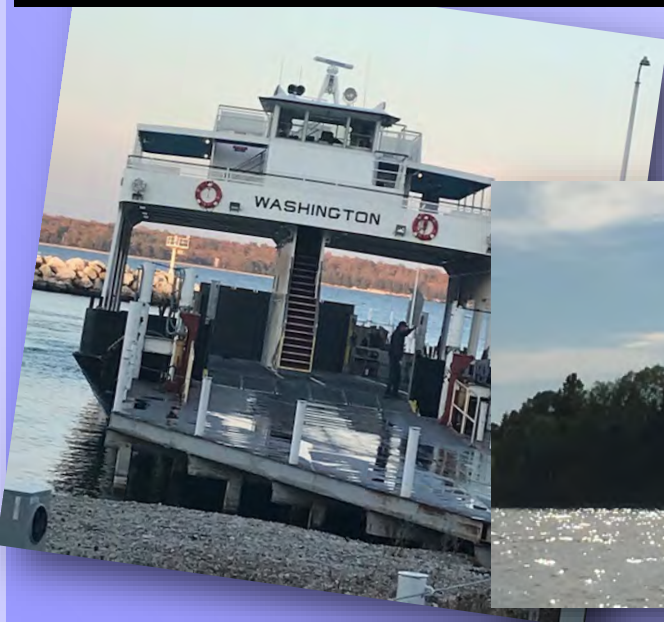
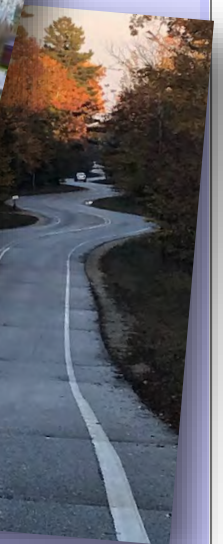

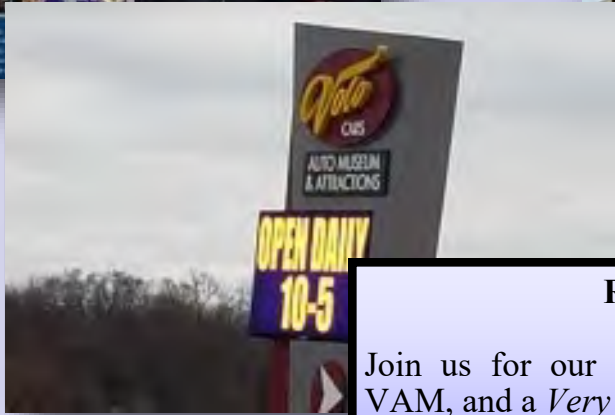

Ride, Rock and Rumble!
June 11th, 2023!
Join us for our 26th Annual Charity Ride! Bike Show, VAM, and a *Very Special Cause... NISRA!* Volo is offering us a great deal on their new family friendly layout! Come, bring the family and help to make this a REAL SUCCESS!

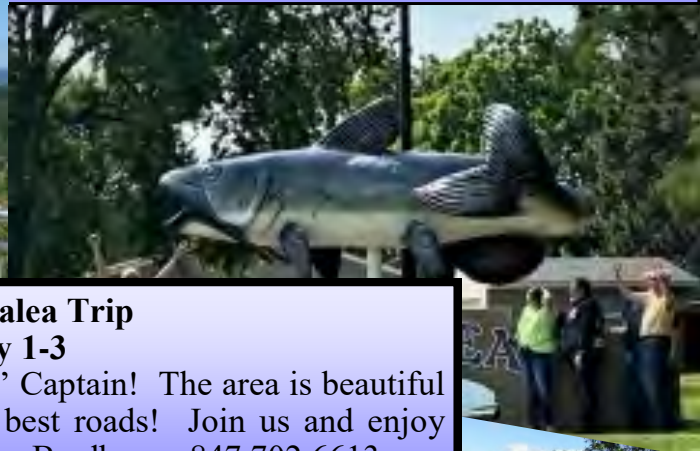
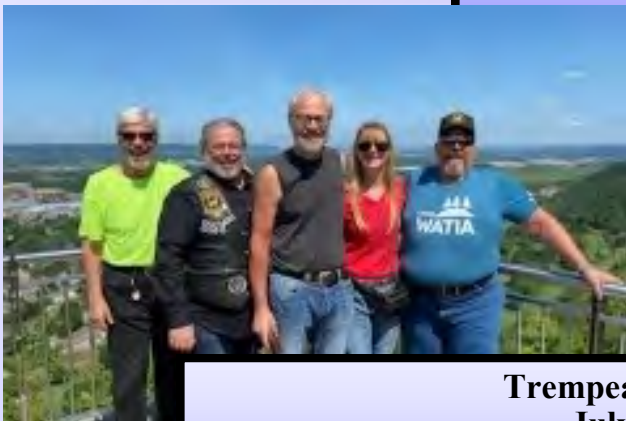

Trempealea Trip
July 1-3
Join another great "Back Road" Captain! The area is beautiful and Mike Bradbury finds the best roads! Join us and enjoy this wonderful event! Call Mike Bradbury: 847.702.6613

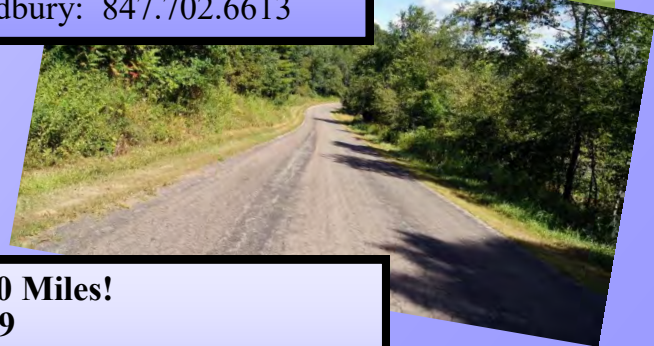

I will Ride 500 Miles!
July 8-9
Get your buns ready for baking on a 500 mile run... just because! Gene Rigsby will lead to Duluth, Minnesota to test stamina! It's fun to know how far you can go!
Call Gene: 847.770.9436



General Membership Meeting Minutes May 2nd, 2023

Respectfully Submitted
by: Diana Lanute

President's Section: Gene Rigsby

- ◆ 7:00 pm, Meeting called to order
- ◆ Pledge of Allegiance
- ◆ Announcements
 - 5/11 – Stefan Maca B-Day
 - 5/22 - Daniella Maca B-Day
 - 5/11 - Bradbury's anniversary
- ◆ Guests – None.

V.P.: Ric Case

- ◆ Progressive dinner ride – This was one of our most popular rides. If interested, maybe we can resurrect this ride.

Past President: Wayne Kirkpatrick

- ◆ During a call with Juergen, Wayne learned the state of affairs with Germany and Ukrainian's living on their streets; gas price is now \$8.40/gallon; and, one rear bike tire will cost over \$500.

Safety: Mike Bradbury

- ◆ - This is Motorcycle Safety Awareness Month
- ◆ Kaution Korner Safety Tip - (Wayne) - (on deck for June) – Slow down to be seen.
- ◆ Kaution Korner – Don – Helmets – Check your inside liner. Rain Gear – Throw out black and replace with bright colors! Don't buy cheap, pay more – it lasts longer! Gloves – Wear neoprene gloves to keep hands dry. Heated gear? – Try on now; maybe you gained weight and it won't fit. Boots – Wear socks. If boots need soles get neoprene.
- ◆ May 2023 is Motorcycle Safety Awareness Month - Mike B - Start recognizing bikes on road with cars. Observe all laws: 34% of all accidents involve motorcycles. Don't ride if impaired. Motorcyclist are 28 times more than car occupants to die in a crash, and 4 times more likely to be injured in an accident compared to car occupants.

Membership: Ted Makarewicz (Abs)

Activities: Rick Agrimonti / Greg Smith

- ◆ Recent activities
 - 4/23 - Kick-off ride – Gene Some showed up.
- ◆ Future activities
 - 5/20 - Picnic Ride - Rigsby's
 - 5/27 - Potosi - Tom Malia – Leave 7:30-8:00am. Return by 6pm.

- 6/2 - Door County Ride – Greg Smith to lead through Milwaukee to Door County. Head home on third day.
- 6/11 – Ride, Rock and Rumble – Rich Lanute and MaryKirkpatrick
- 7/1-3 – Trempeleau, SI - Mike Bradbury – Using Rt 14, stop at LaCross for apple blossom scenic ride, then pizza lunch. Return on Monday on Rt 33; will do Weld Cat Mountain on way back.
- 7/8 & 7/9 – Gene – Head to Duluth. Stay in Ashland, WI. Come back Sunday using country roads.
- Sturgis/FRR updates as need - Wayne/Bard – Need commitment by June 1st.
- Front Range Ride – 8/8 – 8/14 – Anyone interested, let Wayne know.
- 5/27 - 28 Rolling Thunder events

Charity: Rich Lanute and Mary Kirkpatrick R3 (Ride for Dreams 6/11/2023)

- ◆ Rich – Will need to get TC members list for registration. I have data base to send out flyers, etc. Does anyone have any little thing to donate and use as a Raffle Prize? At Board Meeting I will have everything ready for approval.
- ◆ Mary – Will have rub off cards and deck of cards for Lucky Card game.

Products: Get your gear now!! Ted Makarewicz(Abs)

- ◆ Mike Bradbury says that Lands End site is done – use Beta Direct. Logo is Board approved for items we can purchase.

50/50 Raffle: Andy Hasztrakiewicz

Meeting Adjourned by Gene Rigsby, President of Top Cats Illinois at 7:40





Board Meeting Minutes May 9th, 2023

Respectfully Submitted
by: Gene Riggsby for
Diana Lanute

President's Section: Gene Riggsby

- ◆ Meeting called to order 7pm
- ◆ Immediate needs? None.

Past President: Wayne Kirkpatrick

- ◆ Open discussion: Wayne noted that there were no 2023 pictures on our website. Mary talked to Roberta about our drop box.

VP: Ric Case

- ◆ Open discussion on upcoming events

Treasurer: Don DeLordo

- ◆ Report/review: Ride, Rock and Rumble checks made out to TC and mailed to Don.

Activities: Greg Smith

- ◆ Greg reviewed upcoming rides. No activities in Sept yet
- ◆ Calendar review - Mar/Apr/May, etc.
 - ◆ 5/20 - The Presidents Progressive Pick-up Picnic Ride - Gene
 - ◆ 5/27 - Potosi - Tom
 - ◆ 6/2 - 6/4 - Door County Dreaming - Greg/Mary
 - ◆ 6/11 - Ride, Rock and Rumble - Rich/Mary

Safety/RC: Mike Bradbury

- ◆ Mike had no tips to report this month.

Membership/Products: Ted Makarewicz

- ◆ Put applications out for Woodstock Harley Davidson shoppers to take to fill out.

Charity: Rich Lanute

- ◆ R3, Ride for Dreams date – Rich and Mary are working on it.
- ◆ Greg will help Rich with setup at Woodstock and Volo.
- ◆ Ted to look at waiver forms.
- ◆ Allocate money for Lottery tickets: \$25-50 value. Bike Show is in good position.
- ◆ Raffle items: Anybody with ideas – advise. We have a pretty good data base for Ted. Mike B will follow with reminders for all.
- ◆ Rich will email for confirmation from involved members.

- ◆ Wayne to do safety meeting and Pledge of Allegiance for our charity ride.
- ◆ Printing charges? Covered by MC Lawyers? **Rich is following up with the MC**
- ◆ Idea: Chi-Town Harley might have interest in our Charity Event.

Secretary: Diana Lanute had no additions for tonight's meeting.

Meeting Adjourned at 7:45 by Gene Riggsby



**Blasts
from
Charities
Past!**





G.R.A.S.S. CLASS FOR 2023

We have 3 dates for the G.R.A.S.S. Class this year! See the chart below and add these to YOUR calendar!

Come and learn how we ride as a group! All riders, co-riders, non-riders are welcome and all motorcyclists from our great Motorcycling Community are welcome!

If we can train other riders to ride more safely, we all benefit!

Reach out to your motorcycle friends and everyone else in the motorcycle community and invite them to come too! Watch for BLASTS for each date!

LOCATION	DATE
Keller Williams Success! 600 Hart Rd. #105 Barrington, Il 60010	Success! Sunday, March 26, 2023
American Legion Post 911 515 S. Main St. Wauconda, Il 60084	Saturday, July 22, 2023
Keller Williams 600 Hart Rd. #105 Barrington, Il 60010	Sunday, October 22, 2023

Directions into the Keller Williams site:

Enter in the main door and the first door on your left is the Keller-Williams offices. G.R.A.S.S. will be presented in the conference room at the back of the office.

Directions into the American Legion Post 911 site:

Through the main door and Immediately to your left!

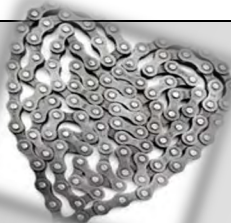

June Birthdays and Anniversaries!

10 Joey Rizzo
25 Bard Board

Happy Days to our Top Cats Celebrities for June!

Let us know your special dates so that we can celebrate with you!

10 Mike and Kathie Bradbury
(That's all we know! Tell us if we're wrong!)



*Top Cats Buy, Sell, Trade....
The best way to ensure good quality at fair prices!*

GREAT DEALS!

Put your items here and get the word out that you have stuff to sell!





TOP CATS BUSINESS MART

BUSINESSES OWNED AND/OR MANAGED BY TOP CATS MEMBERS

kw SUCCESS REALTY

KELLERWILLIAMS.

Mary Kirkpatrick

Realtor

262-344-6228

e: marykirkpatrick@kw.com

w: MaryKirkpatrick.kw.com



600 Hart Road, Suite 105
Barrington Illinois 60010



Each Office Is Independently Owned and Operated



Network with your fellow Riders here...

And Be Thankful!



Support the TOP CATS Patrons



Woodstock HD and Staff Support our Top Cat's Ride for Dreams!



PALATINE, IL

Home to Alley 64,
Top Cat's Monthly Meeting Spot!

Membership Has Its Privileges!

GRASS Classes are held at the Keller -Williams Offices!

All suppliers and vendors who support the Top Cats by providing support to Top Cats members will be listed in ROAR.

Thanks, Greg for supporting our Top Cat's Safety Class!

Sign-up your favorite merchant today!



Greg Smith

**Keller -
Williams
Success
Realty**

**600 Hart Rd.
Suite 105
Barrington, IL
60010**

847.870.0957

Have one of our own Top Cats work with you to buy or sell your home!

NISRA Families have so many wonderful opportunities because of the NISRA staff...
Can we find ways to continue to help them?





RIDES & EVENTS

Date	Ride/Event	Location	Destination	Time	Leader
Friday—Sunday, June 2nd - 4th	Door County Dreamin'	BP Wauconda	Door County, Wisconsin	7:30 am	Smith/ M Kirkpatrick
Tuesday, June 6th	General Meeting	Palatine	Alley 64	7:00 pm	Rigsby
Sunday, June 11th	Ride, Rock and Rumble Charity Ride!	Woodstock Harley Davidson	Volo Auto Museum	8:00 am	Lanute
Tuesday, June 13th	Board Meeting	Palatine	Alley 64	7:00 pm	Rigsby
Friday, July 1st — Sunday July 3th	Trempeleau	Speedway, Hwy 12 Volo	Coulee and Driftless Region of Wisconsin	8:15 AM	Bradbury
Saturday, July 8th— Sunday July 9th	I would ride 500 Miles!	Shell Station 2070 Shell Dr. Libertyville	Duluth, MN	8:00 Am	Rigsby
Tuesday, July 11th	General Meeting	Palatine	Alley 64	7:00 PM	Rigsby
Saturday, July 22nd	GRASS Class	Wauconda	American Legion Post 911	8:30 AM	Bradbury/ Case
Sunday, July 30th	Start out for Sturgis	BP at 12 and 176	Sturgis	8:00 AM	Boand

All ride and event information along with the Photo Gallery can be found at
www.TopCats.org.



Barrington Library

Location and Hours
505 N. Northwest Highway
Barrington, IL 60010

847-382-1300
balibrary.org

See the Top Cats Archive

FREE ADVERTISING in ROAR for TOP CATS Business Owners

Attention all Top Cats business owners!

As part of our ongoing philosophy to support our members and goal to provide a more value-rich publication, we are now offering free advertising space in ROAR for Top Cats business owners. Each business owner can submit advertising content and graphics up to 2 X 3.5 inches (Business Card size) for their company.

We will run the ad for 3 months after which you will need to resubmit it.

This offer is for Top Cats business owners only. We are not accepting advertising for other businesses at this time.

Submit your ad along with contact information to the ROAR editors at ROAR@TOPCATS.org



ROAR



TOP CATS OF ILLINOIS is a group of motorcycle enthusiasts with similar interests. Members consist of responsible Leaders, Presidents, Chairmen, Owners, Proprietors, Partners, principals, CEO's, and other 'Top Cats' of large, medium and small organizations, institutions, and companies.

For more information about the Top Cats visit our website at www.TopCats.org

ELECTED OFFICERS & DIRECTORS		COMMITTEE LEADERS		ROAR	
President	Gene Rigsby- gene.rigsby@gmail.com	Activities	Greg Smith GregSmith@kw.com	Executive Editor & Board Liaison	Mary Kirkpatrick Mawalters57@gmail.com
Vice President	Ric Case Riccase@Comcast.net	Archives	Open	Editor-in-Chief	Mary Kirkpatrick mawalters57@gmail.com
Treasurer	Don DeLordo Don_De@att.net	Charity	Mary Kirkpatrick Mawalters57@gmail.com	Publisher	Open
Secretary	Diana Lanute Diana.Lanute@att.net	Membership	Ted Makarewicz Hogski@hotmail.com	ASSOCIATE EDITORS	
Past President	Wayne Kirkpatrick wkirkpa177@aol.com	Awards	Mike Bradbury bradbundy@comcast.net	Executive & Board	Wayne Kirkpatrick wkirkpa177@aol.com
Director	Rich Lanute Richard.Lanute@att.net	Safety	Mike Bradbury bradbundy@comcast.net	Safety & Road Captains	Mike Bradbury bradbundy@comcast.net
Director	Greg Smith GregSmith@kw.com	Website	Mary Kirkpatrick mawalters57@gmail.com	Membership	Ted Makarewicz Hogski@hotmail.com
Director	Mike Bradbury bradbundy@comcast.net	Products	Ted Makarewicz Hogski@hotmail.com	Charity	Mary Kirkpatrick Mawalters57@gmail.com
Director	Ted Makarewicz Hogski@hotmail.com	SGT at Arms	Andy Haszlakiewicz andyh9946@gmail.com	Events & Calendar	Greg Smith GregSmith@kw.com & Rick Agrimonti Rickandyolie@att.net
Founder	Carl 'Virgo' Bender 1941-2001			Motorcycle Community	Wayne Kirkpatrick wkirkpa177@aol.com

© Copyright 2010 **TOP CATS OF ILLINOIS**
ROAR is the official publication of the **TOP CATS OF ILLINOIS**
and is published on the 1st of each month.

The content and opinions expressed in articles are those of the authors and not necessarily those of **TOP CATS OF ILLINOIS**

For questions or to submit comments or articles for publication, contact the editors at ROAR@TopCats.org